

## Research Article

# Analysis of Development in Solar Greenhouses

Abdeen Mustafa Omer

Energy Research Institute (ERI), Nottingham, United Kingdom

### Article History

Received: 06.05.2020

Accepted: 15.06.2020

Published: 27.06.2020

### Journal homepage:

<https://www.easpublisher.com/easjrit>

### Quick Response Code



**Abstract:** The move towards a de-carbonised world, driven partly by climate science and partly by the business opportunities it offers, will need the promotion of environmentally friendly alternatives, if an acceptable stabilisation level of atmospheric carbon dioxide is to be achieved. The use of natural resources that have not any air pollution or greenhouse gases and provides comfortable coexistence of human, livestock, and plants. The greenhouses require air conditioning process to control their temperature and relative humidity to suit specific plants. To achieve this goal, a novel air humidifier and/or dehumidifier systems using mop fans had been designed and employed in an experimental greenhouse to evaluate its performance under a controlled environment. The mop fan help to reduce the energy consumption of the greenhouse whilst providing a pleasant environment for the plants inside the greenhouse. The system was designed taking into account the meteorological conditions, which affect the environment inside the greenhouse. The performance of the system was monitored over a period of time by measuring the temperature and relative humidity of the greenhouse. Results of the monitoring have shown that the system was able to provide comfortable conditions (temperatures of 16-26°C and relative humidity of 65%) suitable for the plants grown in the experimental greenhouse. This device enable to minimise the temperature variation and, hence, avoided the hazard of any sudden climatic change inside the greenhouse.

**Keywords:** Solar energy, greenhouses, solar radiation, global radiation

**Copyright © 2020 The Author(s):** This is an open-access article distributed under the terms of the Creative Commons Attribution **4.0 International License (CC BY-NC 4.0)** which permits unrestricted use, distribution, and reproduction in any medium for non-commercial use provided the original author and source are credited.

## Introduction

Increasing awareness of the environmental impact of CO<sub>2</sub>, NO<sub>x</sub> and CFCs emissions triggered a renewed interest in environmentally friendly cooling, and heating technologies (Levine, M., & Hirose, M. 1995).

The way to reduce building energy consumption is to design buildings, which are more economical in their use of energy for heating, lighting, cooling, ventilation and hot water supply consumption (Energy use in offices. 2000). The provision of good indoor environmental quality while achieving energy and cost efficient operation of the heating, ventilating and air-conditioning (HVAC) plants (devices) in buildings represents a multi variant problem. The comfort of building occupants is dependent on many environmental parameters including air speed, temperature, relative humidity and quality in addition to lighting and noise. The overall objective is to provide a high level of building performance (BP), which can be defined as indoor environmental quality (IEQ), energy efficiency (EE) and cost efficiency (CE).

- Indoor environmental quality is the perceived condition of comfort that building occupants experience due to the physical and psychological conditions to which they are exposed by their surroundings. The main physical parameters affecting IEQ are air speed, temperature, relative humidity and quality.
- Energy efficiency is related to the provision of the desired environmental conditions while consuming the minimal quantity of energy.
- Cost efficiency is the financial expenditure on energy relative to the level of environmental comfort and productivity that the building occupants attained. The overall cost efficiency can be improved by improving the indoor environmental quality and the energy efficiency of a building.

However, because renewable energy sources are stochastic and geographically diffuse, their ability to match demand is determined by adoption of one of the following two approaches (Energy use in offices. 2000): the utilisation of natural resources by the community to be supplied, or the reduction of the community's energy demands to a level commensurate with the locally available renewable resources.

For an average wind speed of  $5 \text{ ms}^{-1}$ , the power produced by a micro wind turbine will be of a similar order of magnitude, though with a different profile shape. In Europe for example, the office buildings will have a demand in the order of  $300 \text{ kWhm}^{-2}\text{yr}^{-1}$  (DETR. 1994) to greenhouses, which use solar energy to provide indoor environmental quality. The greenhouse effect is one result of the differing properties of heat radiation when it is generated at different temperatures. Objects inside the greenhouse, or any other building, such as plants, re-radiate the heat or absorb it. Because the objects inside the greenhouse are at a lower temperature than the sun, the re-radiated heat is of longer wavelengths, and cannot penetrate the glass. This re-radiated heat is trapped and causes the temperature inside the greenhouse to rise. Note that the atmosphere surrounding the earth, also, behaves as a large greenhouse around the world. Changes to the gases in the atmosphere, such as increased carbon dioxide content from the burning of fossil fuels, can act like a layer of glass and reduce the quantity of heat that the planet earth would otherwise radiate back into space (Bos, E. *et al.*, 1994; Duchin, F. 1995; World Energy Outlook. 1995; DEFRA. 2002; Parikh, J. *et al.*, 1999; VAN Schijndel, P. *et al.*, 1998; & IPCC. 2001). This particular greenhouse effect, therefore, contributes to global warming. The development of greenhouses could be a solution to farming industry and food security (UNIDO. 1997; WRI (World Resource Institute). 1994; & Dincer, I. 2002).

The present work highlights energy using and energy saving technologies in farming, horticulture, livestock production, crop conservation, crop storage, supplementary lighting, and energy efficient technologies available to farmers and plants growers. Examples include dehumidification, horticultural lighting, and environmental control for healthy plants and livestock. Typical applications include parlour ventilation and fly control, calf pens, poultry houses, pig and sheep units, potato stores, greenhouses, and packing sheds. The benefits to the farming industry are demonstrated at a small-scale by experiments conducted in a greenhouse designed and constructed at Nottingham University as part of the study. The research, also, highlights some alternative methods to be implemented for sustainable development through using clean, environmentally friendly devices as alternatives in order to harness natural resources. These include the following:

- Employing novel air humidifier and/or dehumidifier systems using mop fans for control of indoor humidity and temperature in greenhouses.
- Using of a novel absorbent material to enhance the performance of the system, hence reducing energy consumption.
- Investigating low cost materials for applications in greenhouses.
- Introducing new coating materials for greenhouse use.

With increasing urbanisation in the world, cities are growing in number, population and complexity. At present, 2% of the world's land surface is covered by cities, yet the people living in them consume 75% of the resources consumed by mankind (Rees, W.E. 1999). Indeed, the ecological footprint of cities is many times larger than the areas they physically occupy. Economic and social imperatives often dictate that cities must become more concentrated, making it necessary to increase the density to accommodate the people, to reduce the cost of public services, and to achieve required social cohesiveness. The reality of modern urbanisation inevitably leads to higher densities than in traditional settlements and this trend is particularly notable in developing countries.

Today, the challenge before many cities is to support large numbers of people while limiting their impact on the natural environment. Buildings are significant users of energy and materials in a modern society and, hence, energy conservation in buildings plays an important role in urban environmental sustainability. A challenging task of architects and other building professionals, therefore, is to design and promote low energy buildings in a cost effective and environmentally responsive way. Passive and low energy architecture has been proposed and investigated in different locations of the world (Yuichiro, K. *et al.*, 1991; & Givoni, B. 1994); design guides and handbooks were produced for promoting energy efficient buildings (CIBSE. 1998; FSEC. 1998; State Projects. 1993; & Watson, D. editor. 1993). This may help people study and improve the quality of built environment and living conditions.

However, the term low energy is often not uniquely defined in many demonstration projects and studies (Abdel, E. 1994). Yet, sometimes the target may focus on the energy costs or a particular form of energy input to the building. Since many complicated factors and phenomena influence energy consumption in buildings, it is not easy to define low energy building precisely and to measure and compare the levels of building energy performance. The loose fit between form and performance in architectural design also makes quantitative analysis of building energy use more difficult. Nevertheless, it is believed that super-efficient buildings, which have significantly lower energy consumption, can be achieved through good design practices and effective use of energy efficient technology (Todesco, G. 1996).

The first one is the transport energy requirements as a result of the building and urban design patterns and the second one is the embodied energy or energy content. Transport energy is affected by the spatial planning of the built environment, transport policies and systems, and other social and economic factors. It is not always possible to study the

effect of urban and building design on transport energy without considering the context of other influencing factors. The general efficiency rules are to promote spatial planning and development, which reduce the need to travel, and to devise and enforce land-use patterns that are conducive to public transport (Owens, S. 1986). Embodied energy, on the other hand, is the energy input required to quarry, transport and manufacture building materials, plus the energy used in the construction process. It represents the total life-cycle energy use of the building materials or systems and can be used to help determine design decisions on system or materials selection (Treloar, G. J. *et al.*, 1998). Research findings in some countries indicate that the operating energy often represents the largest component of life-cycle energy use.

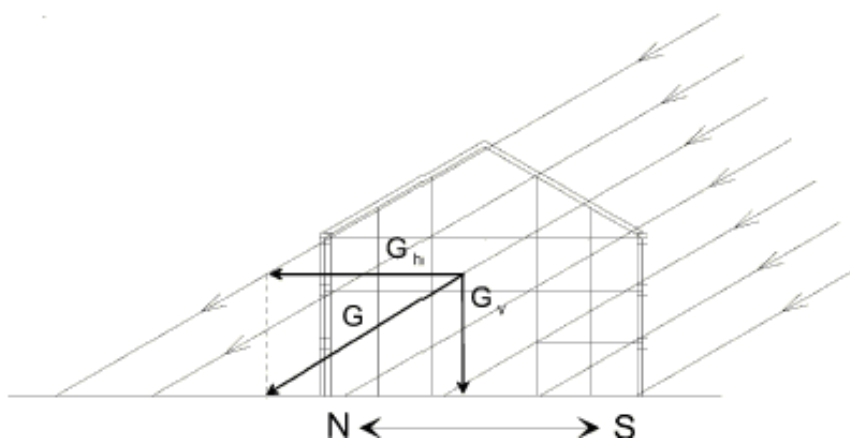
### Solar Power

Enhancing the insolation for other purposes has, so far, scarcely been used. Several years ago, application of this principle for increasing the ground irradiance in greenhouses, glass covered extensions in buildings, and for illuminating northward facing walls of buildings was proposed (Achard, P., & Gicquel, R. 1986). Application of reflection of sun's rays was motivated by the fact that ground illuminance/irradiance from direct sunlight is of very low intensity in winter months, even when skies are clear. This is even more pronounced at greater latitudes. As can be seen in Figure 1, which depicts a sunbeam split into its vertical and horizontal components, nearly all of the radiation passes through a greenhouse during most of the day.

Diffuse solar radiation contributes to most of the ground irradiation. Other authors were also aware of this fact and have attempted to increase the average irradiance in a greenhouse by reflecting to the ground a part of the direct sunlight, which otherwise passes through the glass roof and walls (Kurata, K. 1983a; Kurata, K. 1983b; Critten, D. 1985; Critten, D. 1986; & Andrews, R. 1982). Thus, Kurata (Kurata, K. 1983a) applied Fresnel prisms to greenhouse coverings in order to divert some of the light towards the ground, and made use of reflection from the back wall (Kurata, K. 1983). Critten (Critten, D. 1985; & Critten, D. 1986) investigated the effect of highly reflective Venetian blinds hung underneath the roof of a single span greenhouse, while Andrew, Bailey and Cotton (Andrews, R. *et al.*, 1982) applied the same to the northern wall of a greenhouse. However, they limited their considerations to constructions adapted to existing greenhouses. Moreover, they neglected the effects of azimuth angles different from zero, and calculated the gains only in situations when the sun shone from the south (at noon). In fact, major reductions of potential gains from reflected radiation occur in morning and evening hours when the azimuth angles of incoming sunlight are large. This suggests that night ventilation could be improved, and incorporating a combined wall-roof solar chimney increases the cooling load.

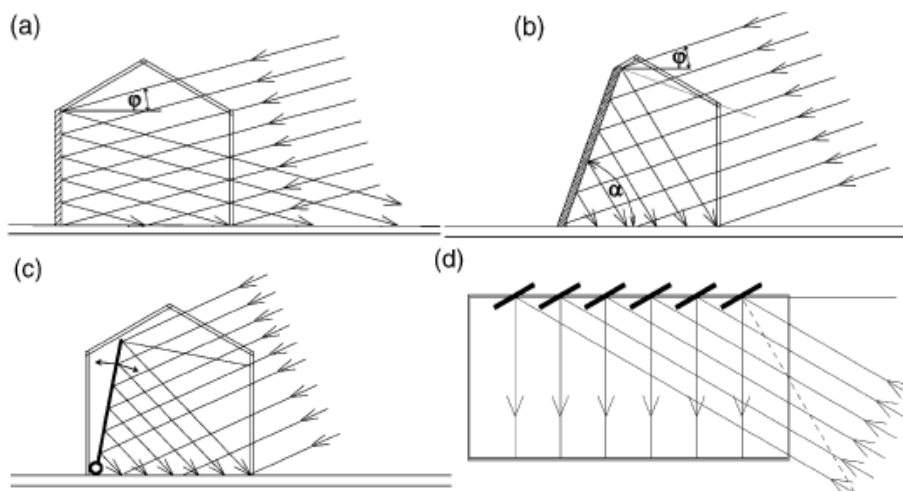
The possibility of capturing the horizontal component of sun's rays that merely passes through a greenhouse, and of reflecting it to the ground was explored. Different ways of diverting most of the radiation and using it inside the greenhouse throughout an entire day were examined. Four different types of greenhouses, in orders of increasing sophistication were investigated (Figure 2). These are:

- [1] A classical greenhouse, in which a vertical section of its northern wall was covered by a reflecting material (e.g., aluminum foil, and metalisation spraying of existing glass).
- [2] A specially constructed greenhouse with its northern wall inclined at an optimum angle and covered with a reflecting material intended for directing sunlight towards the ground.
- [3] A classical greenhouse with a reflecting panel placed on the northern wall whose inclination could be changed by a special mechanism in order to provide maximal returns with changing incident angles of the sun throughout the day.
- [4] A greenhouse with a reflecting wall divided into vertical sections (louvers), which could rotate on a vertical axis so as to provide maximal returns with changing azimuths of sun's angles.



**Figure 1.** Relative horizontal and vertical components of solar radiation.

Use of that particular country. It is not surprising that people want to improve their quality of life. Consequently, it is expected that the demand for commercial energy resources will increase at a greater The quality of life practiced by people is usually represented as being proportional to the per capita energy rate in the years to come.



**Figure 2.** Greenhouse types according to the applied mode of reflection of solar radiation: (a) fixed vertical reflecting wall (b) fixed inclined reflecting wall (c) reflecting wall with variable inclination (d) reflecting wall with louvers.

Each type of greenhouse could achieve significant increases of ground insolation. It should be larger the sun is, and from dawn to dusk enhancements of ground illuminance and/or irradiance should be higher the lower the maximal incident angle is for a particular day. Conversely, the reflecting wall obstructs a part of the diffuse radiation, increasingly lowering its contribution to the overall irradiance; the more inclined the wall is.

**Effects of the Incident Angle of Sunlight**

In general irradiance of the ground in classical greenhouses is given by:

$$G_G^S = G_o^S(\varphi) \sin\varphi \quad (1)$$

And, for given conditions of the sky described by the value  $G_o^S(\varphi)$ , it depends on the elevation angle of the sun only. It is understood that factor,  $G_o^S(\varphi)$  which is the illuminance or irradiance at an incident angle of sunrays of 90° (normal illuminance/irradiance), is a complex quantity that depends on the atmospheric conditions at the moment when the observation/measurement is made (Perez, R. *et al.*, 1990). However, as the purpose of this analysis was to evaluate the possible degree of enhancement of either quantities (illuminance or irradiance) after application of a given reflecting wall (reflector), only geometric factors were considered in the following derivations. Reflection of sunrays from a reflector is shown schematically in Figure 3. The vertical width of the light beam reflected from a wall with either type (a) or (b) reflectors of height h is:

$$S_v = h \sin(\alpha - \varphi) \quad (2)$$

So that the total light reflected to the ground is:

$$(G_R^S)' = G_o^S(\varphi) \rho S_v = G_o^S(\varphi) \rho h \sin(\alpha - \varphi) \quad (3)$$

Extending on the ground to a distance of:

$$x_o = h \sin(\alpha - \varphi) / \sin(2\alpha - \varphi) \quad (4)$$

Hence, the illuminance/irradiance arising from the reflection is:

$$G_R^S = (G_R^S)' / x_o = G_O^S(f) r \sin(2\alpha - 3) \quad (5)$$

The total ground illuminance/irradiance in parts of the greenhouse illuminated by reflected direct sunlight is the sum of the two values:

$$G_T^S = G_G^S = G_R^S = G_O^S(\varphi) \rho \sin(2\alpha - 3) \quad (6)$$

Eq. (6) covers greenhouse types (a) and (b), the difference between them solely being the value  $\alpha$ . In greenhouse type (c) and (d)  $\alpha$  is adjusted so that the distance  $x_o$  remains constant and equal to the width of the greenhouse,  $a$ . In the latter case, one can derive that for any  $\varphi$ , the inclination angle  $\alpha$  must be:

$$\alpha = 60 + (2/3) \varphi \quad (7)$$

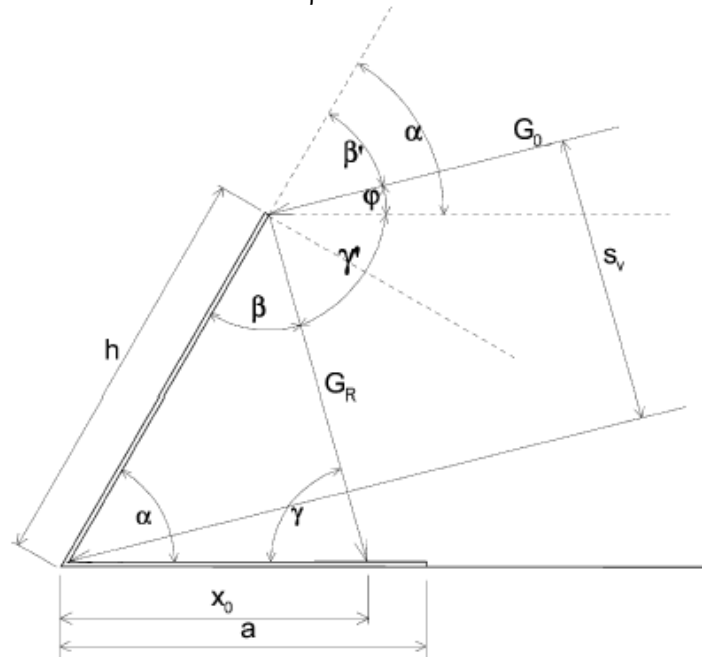
Hence, introducing Eq. (7) into Eq. (6), one obtains for greenhouse types (c) and (d):

$$G_T^S = G_O^S(\varphi) [\sin \varphi + \rho \sin(120 - \varphi/3)] \quad (8)$$

On the basis of the later derivations (Eq. 8) the ground irradiance due to reflections is obtained from Eqs. (6) or (8) and (1) as:

$$\eta_s = \frac{G_T^S}{G_G^S} \quad (9)$$

Whereby the normal illuminance/irradiance cancel out.  $\rho$  is reflected coefficient of the wall.



**Figure 3.** Schematic representation of the reflection of a sunbeam to the ground of a greenhouse with a reflecting wall.

### Average Irradiance and Total Energy Gain of a Greenhouse from Direct Sunlight

On a clear day sunlight impinges on a greenhouse at different azimuth angles. The change in the angle does not affect ground irradiance. At different situation is observed with a reflected beam. In type (a) and (b) greenhouses there are reasons why reflected light at certain hours of the day does not illuminate the entire ground-surface: at high incident angles the spread of the reflected beam to  $x_o$  may be smaller than the width of the greenhouse,  $a$ , i.e.,  $x_o/a < 1$ . In this case a portion of the ground towards the front is illuminated by direct sunbeams only. Hence, the average illuminance/irradiance of the ground in this case is:

$$G_{T,av}^S = G_G^S + (x_o/a)G_R^S = G_O^S(f)[\sin f + r \sin(a - f)] \quad (10)$$

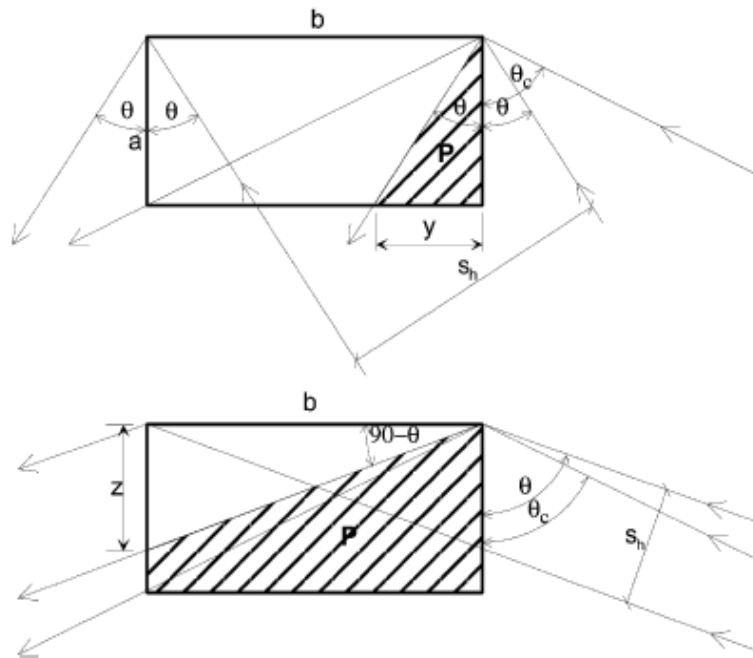
Obviously, when  $x_o > a$ , Eqs. (6) or (8) are applicable.

Also, as seen in Figure 4, with increasing  $\theta$  the horizontal width of the sun's rays becomes increasingly reduced so that:

$$S_h = b \cos \theta \quad (11)$$

And now the illuminance/irradiance arising from reflection is:

$$G_R^S = G_O^S(f)r \sin(2a - f) \cos(q) \quad (12)$$



**Figure 4.** Influence of the azimuth angle  $\theta \neq 0$  on the effectiveness of exposure of the ground to reflected light.

Moreover, the radiation misses a part of the ground area. For a greenhouse with a ground surface  $S_o$  (i.e., dimensions,  $axb$ ), the relative part of the illuminated area is:

$$\frac{S}{S_o} = [ab - (a^2/2) \tan q] / ab = 1 - (a/2b) \tan q \quad (13)$$

And for  $\theta > \theta_c$

$$S / S_o = \frac{(b^2/2)}{ab} \cos q = (b/2a) / \tan q \quad (14)$$

Where  $\theta_c = \arctan (b/a)$ , so that the total reflected radiation received by the ground of the observed greenhouse is

$$G_R^S (S / S_o).$$

The average ground irradiance over the entire ground area is thus:

$$G_{T,av}^S = G_G^S + (S / S_o)G_R^S \quad (15)$$

In a type (d) greenhouse a louver should be oriented so that all of the reflected light falls onto the ground area of the greenhouse. This is achieved by fixing the louver at an angle  $(90+\theta/2)$ , with respect to the axis at  $\theta=0$ . In this case the

angle  $\theta$  in Eqs. (12)-(14), are replaced by  $\theta/2$ . In considering the overall (average) enhancement as a result of the reflection principle these effects must be taken into account. Therefore, the overall enhancement coefficient should be:

$$\eta_w = G_{T,av}^S / G_G^S \quad (16)$$

The greenhouse of prime importance also to assess the energy it gains from direct illumination during an entire day, from sunrise to sunset. This is obtained by integrating Eq. (15):

$$G_T^S = 2 \int_{\tau_1}^{\tau_2} G_{T,av}^S d\tau \quad (17)$$

Where  $\tau_1$  and  $\tau_2$  refer to the times of sunrise and noon, respectively. Also, the energy enhancement coefficient can be calculated from:

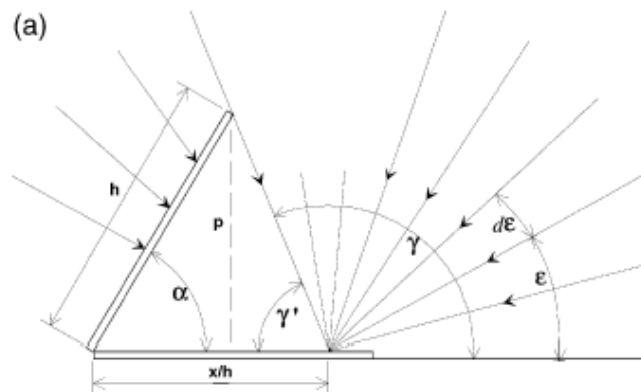
$$h_{wh}^S = Q_T^S / Q_G^S \quad (18)$$

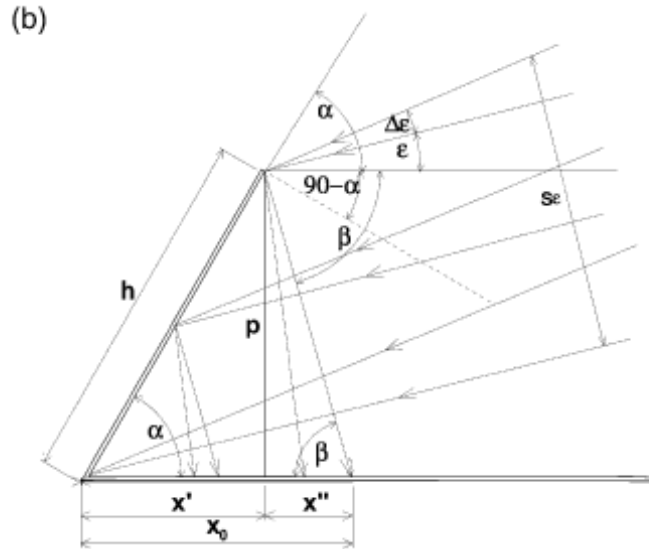
**The Effect of Diffuse Radiation**

A contribution to the ground radiation in a classical greenhouse arises from diffuse light from the entire sky hemisphere. This amounts to an integral of diffuse radiation arriving from all incident angles of elevation, from  $0^\circ$  to  $180^\circ$ , and of azimuths ranging from  $0^\circ$  to  $360^\circ$ . Two cases of diffuse radiation are presently analysed: isotropic (from an evenly cloudy sky), and anisotropic (from a clear sky). The implication from the two extremes is that a real situation would most of the time lie somewhere in between. The presence of a reflecting wall reduces access of diffuse radiation to the ground, as shown schematically in Figure 5. Thus, it is obvious that direct contribution of diffuse radiation to ground radiation in a greenhouse with a reflecting wall is smaller than in a classical greenhouse by the shadow of the reflecting wall. However, the reflecting wall also reflects some of the diffuse radiation arriving from the part of the sky not obstructed by the wall. To control the energy used for the cooling of buildings in hot-arid regions with ambient air temperatures during the hottest period between  $42$  to  $47^\circ\text{C}$ , passive cooling approaches should be implemented (Andrews, R. *et al.*, 1982).

Thus, to a first approximation, assuming a homogeneously overcast sky (isotropic case) at any given moment, and at any point at a relative distance  $x/h$  from the wall, the ground receives an integral of the diffuse radiation arriving from all angles  $\epsilon$  between  $0$  and  $\gamma$ .

$$G_G^D(x/h) = G_o^D g(x/h) / 180 \quad (19)$$





**Figure 5.** Schematic representations of (a) diffuse light falling onto a point at distance  $x/h$  from the reflecting wall, and of (b) diffuse light reflected by the wall.

The angle  $\gamma$  is a function of  $x/h$  from:

$$\cot \gamma (x/h) = \cot \alpha - (x/h)/h \sin \alpha \quad (20)$$

It is obvious (Figure 5) that  $\gamma (x/h)$  decreases as the point approaches the wall and so should do the part of ground irradiance arising from diffuse radiation. However, the reflecting wall also reflects diffuse radiation (Figure 5b). The contribution from a part of the sky hemisphere  $d\epsilon$  should be:

$$G_R^D(\epsilon) = \frac{G_O^D}{180} \frac{h \sin(\alpha - \epsilon)}{[h \cos \alpha + (tg \epsilon - b) / (1 + btg \epsilon)]} d\epsilon \quad (21)$$

Where  $G_O^D/180$  is the value of  $G_O^D$  per degree of the sky hemisphere and:

$$b = 2tg\alpha / (1-tg^2\alpha) \quad (22)$$

Hence, the total intensity of diffuse radiation reflected from that part of the hemisphere should be:

$$G_R^D = \int_0^\gamma G_R^D(\epsilon) d\epsilon \quad (23)$$

The calculations show that it increases as the point approaches the wall. The total intensity of ground radiation from diffuse light in a greenhouse with a reflector is the sum of Eqs. (19), and (23):

$$G_T^D(x/h) = G_G^D(x/h) + G_R^D(x/h) \quad (24)$$

The reduction coefficient of the diffuse ground radiation due to introduction of the reflecting wall is:

$$h_D = G_T^D(x/h) / G_O^D \quad (25)$$

This is expected to be less than 1.



**Total Ground Radiation in a Greenhouse with a Reflecting Wall**

The aim of the later derivations (Eq. (25)) is to compare the ground radiation in greenhouses with reflectors with that in a classical greenhouse. The former is the sum of intensities of direct insolation and diffuse incoming radiation from clear or cloudy skies. Thus:

$$G_T = G_T^S + G_T^D = G_G^S + G_R^S + G_G^D + G_R^D \quad (26)$$

Hence, the sum can be obtained by using the values given by Eqs. (1), (12), (19), and (23), or (15) and (24). This sum has to be compared with ground radiation in a classical greenhouse:

$$G_G = G_G^S + G_G^D = G_G^S + G_O^D \quad (27)$$

As obtained from the previously derived  $G_G^S$ , and the constant value of the integral of incoming radiation from the entire sky hemisphere. Thus, the enhancement coefficient, which represents a quantitative answer to the problem set in the introduction, is:

$$\eta_T = G_T / G_G \quad (28)$$

And can be obtained from Eqs. (26), and (27):

$$\eta_T \Rightarrow \frac{G_T^D}{G_O^D} = \eta_D \quad (29)$$

$\eta_T$  is less than 1. This is undesirable from the point of view of ground radiation and energy balance in a greenhouse. The anisotropic case is difficult to treat theoretically as clear sky radiation depends on the position of the sun and is more intense in the vicinity than away from the light source. Hence, the appropriate equations could in this case only be used with experimentally determined  $G_O^D$  values. During winter months in particular, when the sun is low even when at its apex and when cloudy days prevail, diffuse radiation can play a very significant role. For different reasons, a large amount of work has been performed on estimating diffuse radiation under different conditions (Matusiak, B., & Aschehoug, O. 1998; Pucar, M. 1997; Pucar, M. 1999; & Mazria, E. 1979).

**Derivation of the Distance from the Reflecting Wall Traversed by Reflected Radiation  
As seen from Figure 5, reflection at the reflecting wall gives:**

$$\beta = \beta' = \alpha - \varphi \quad (30)$$

Sum of angles equal to 180° gives:

$$\gamma = 180 - \alpha - \beta = 180 - 2\alpha + \varphi \quad (31)$$

Law of sine gives:

$$x_o / \sin \beta = h / \sin \gamma \quad (32)$$

Thus:

$$\begin{aligned} x_o &= h \sin \beta / \sin \gamma \\ &= h \sin (\alpha - \varphi) / \sin (180 - 2\alpha + \varphi) = h \sin (\alpha - \varphi) / \sin (2\alpha - \varphi) \end{aligned} \quad (33)$$

**Derivation of the Angle of Inclination of the Reflecting Wall for Providing Full Exposure of the Greenhouse Ground to Radiation with Changing  $\Phi$**

For the example of  $h=a$ , and for  $x_o=a$

$$\beta = \gamma \quad (34)$$

Thus:

$$\alpha + 2\beta = 180 \quad (35)$$

And as:

$$\beta = \alpha - \varphi \quad (36)$$

Thus:

$$\alpha = 60 + 2\varphi/3 \quad (37)$$

Where  $\beta$ ,  $\gamma$  are auxiliary angles used in Figure 3.  $\alpha$  is inclination angle of the reflecting wall.  $\varphi$  is incident angle of the sun.

### Derivation of Normal Irradiance by Solar Ray $G_o^s(\varphi)$ as a Function of $\Phi$

The distance, which sun's rays must travel through the atmosphere to reach the surface of the earth,  $d$  as a function of  $\varphi$  can be calculated from the triangle shown in Figure 6 where according to the Law of sines:

$$(d/\sin A) = (R/\sin B) = (R + \Delta R)/\sin C \quad (38)$$

As:

$$C = 90 + \varphi \quad (39)$$

$$\sin B = [R/(R + \Delta R)] \sin (90 + \varphi) = [R/(R + \Delta R)] \cos \varphi \quad (40)$$

$$B = \arcsine \{ [R/(R + \Delta R)] \cos \varphi \} \quad (41)$$

Since:

$$A + B + (90 + \varphi) = 180 \quad (42)$$

$$A + B + \varphi = 90 \quad (43)$$

So that:

$$A = 90 - \varphi - B \quad (44)$$

Where A, B, and C angles in the triangle presented in Figure 6.

And, finally:

$$d = (R + \Delta R) \frac{\sin(90 - B - \varphi)}{\cos \varphi} \quad (45)$$

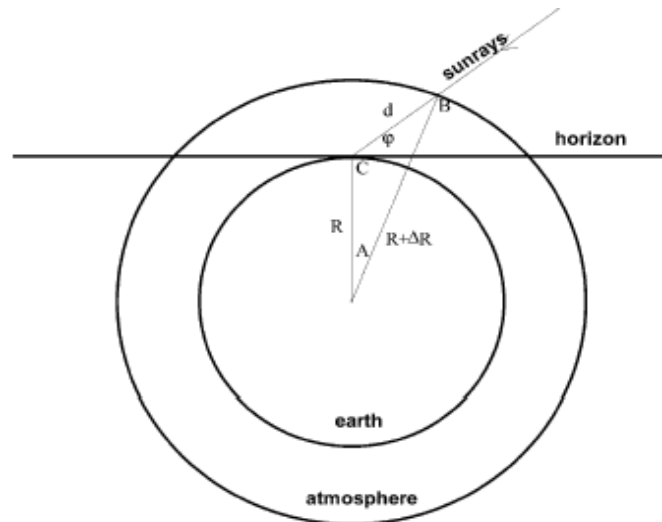
If the irradiance at the outer surface of the atmosphere is  $G_o$ , at the surface of the earth Lambert's Law gives it:

$$\log (G_o^s(\varphi) / G_o) = -\tau d \quad (46)$$

Implying that  $G_o^s(\varphi)$  depends on the value of  $\tau$ .

Where  $G_o^s(\varphi)$  is the solar irradiance (radiation at a plane normal to incident solar rays),  $Wm^{-2}$ .  $\tau$  is the transmission coefficient,  $km^{-1}$ .

Figure 7 describes the change of  $[G_o^S(\varphi) / G_o]$  with  $\varphi$ , from sunrise ( $\varphi=0$ ) to the apex on December 21 ( $\varphi=22^\circ$ ) for different values of  $\tau$ , rendering the values of  $G_o^S(\varphi) / G_o^S(22)$  between 0.5 and 1.0. The radius was taken as 6.378 km and  $\Delta R$  as 100 km.



**Figure 6.** A schematic representations of the earth and its atmosphere with sunrays falling at an inclination  $\varphi$  with respect to the horizon.

**Derivation of the Effect of  $E \neq 0$  on the Extent of Illumination of the Ground**

From Figure 7 it can be seen that there are two different situations for reflected radiation illuminating the ground. Below a certain critical angle  $\theta_c$ , (situation a) the area, which is not illuminated, is:

$$P = (ay/2) = (a^2/2) \tan \theta \quad (47)$$

As  $(y/a) = \tan \theta$  and  $y = a \tan \theta$   
 Hence, the area that remains illuminated is:

$$S = ab - (a^2/2) \tan \theta \quad (48)$$

Or

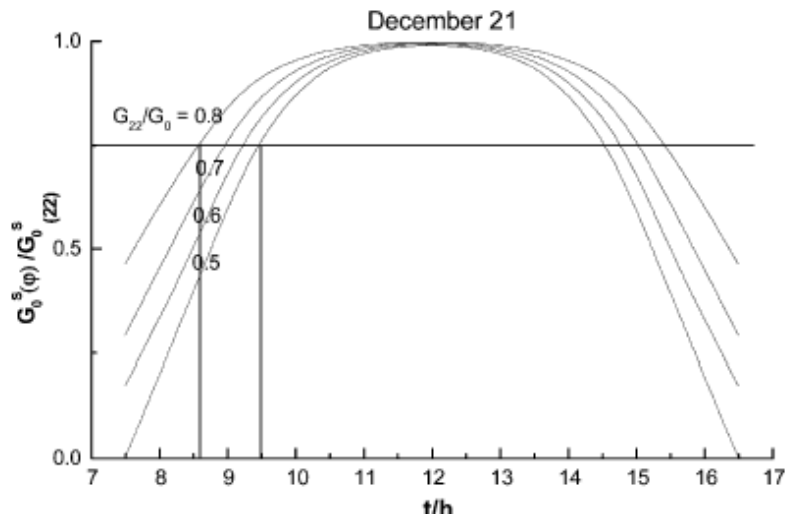
$$(S/S_o) = 1 - (a/2b) \tan \theta \quad (49)$$

Where a and b are the greenhouse width, length respectively.  
 This is valid until a critical azimuth angle is reached, which occurs for:

$$\tan \theta_c = b/a \quad (50)$$

$$\theta_c = \arctan (b/a) \quad (51)$$

When  $S/S_o = 0.5$



**Figure 7.** Calculated values of normal irradiance by solar rays relative to the values obtained at the apex on December 21 for different transmittance by the atmosphere.

Furthermore, when  $\theta$  is larger than the value given by Eq. 50:

$$(z/b) = \tan (90- \theta) = \cot \theta \quad (52)$$

The illuminated part is:

$$S = (zb/2) = (b^2/2) = \cot \theta \quad (53)$$

Hence:

$$S/S_o = (b^2/2) \cot \theta \quad (54)$$

Where  $\theta$  is azimuth angle of the sun, and  $\theta_c$  is critical azimuth angle at which half of the ground area is not receiving the reflected light.

**Ground Irradiation Due to Direct and Reflected Diffuse Radiation**

From rules of geometry one can derive (Figure 5):

$$p = (x/h)/(\cot \alpha + \cot \gamma) \quad (55)$$

As:

$$\gamma' = 180- \gamma \quad (56)$$

$$\cot (180- \gamma) = \cot \gamma' \quad (57)$$

Follows that:

$$p = (x/h)/(\cot \alpha - \cot \gamma) \quad (58)$$

On the other hand

$$(p/h) = \sin \alpha \quad (59)$$

Hence:

$$h \sin \alpha - (x/h)/(\cot \alpha - \cot \gamma) = 0 \quad (60)$$

From which one obtains:

$$\cot \gamma = \cot \alpha - (x/h)/h \sin \alpha \quad (61)$$

For any angle  $\epsilon$  of a cross-section of the hemisphere normal to the reflecting wall (Figure 5b):

$$G_R^D(\epsilon) = (G_O^D)' (S_\epsilon / x_o) \quad (62)$$

Where:

$$(G_O^D)' = G_D^O / 180 \quad (63)$$

And  $S_\epsilon$  is the width of the beam and  $x_o$  is the distance from the wall reached by the reflected beam. Furthermore:

$$S_\epsilon = h \sin (\alpha - \epsilon) \quad (64)$$

And

$$x_o = x' + x'' = h \cos \alpha + h \sin \alpha / \tan \beta \quad (65)$$

$$\beta = 2(90 - \alpha) + \epsilon = 180 - 2\alpha + \epsilon \quad (66)$$

Hence:

$$\tan b = \frac{\tan \epsilon + (2 \tan \alpha) / (1 - \tan^2 \alpha)}{1 + \tan \epsilon (2 \tan \alpha) / (1 - \tan^2 \alpha)} = (\tan \epsilon - b) / (1 + \tan \epsilon) \quad (67)$$

Where:

$$b = 2 \tan \alpha / (1 - \tan^2 \alpha) \quad (68)$$

Substituting Eq. (57) into Eq. (65) and introducing Eqs. (64), and (65) into Eq. (62) one obtains:

$$G_R^D(\epsilon) = \frac{G_D^O}{180} \frac{h \sin (\alpha - \epsilon)}{[h \cos \alpha + (\tan \epsilon - b) / (1 + \tan \epsilon)]} \quad (69)$$

### Ground Irradiance due to Direct Illumination in a Classical Greenhouse

Ground irradiance from direct illumination on a clear sunny day in a classical greenhouse was calculated using Eq. (1). The entity  $G_O^S(\varphi)$  is the value of irradiance normal to the sunbeam. It is a complex function of latitude and altitude, as well as of the inclination angle of the sun during the day, which takes into consideration the fact that solar radiation passes through layers of differing thickness. However, as a first approximation it could be taken as constant in order to demonstrate the trend of change of irradiance under conditions of clear skies. A significant deviation can be expected only in early morning and late evening hours. Excluding the first hour after sunrise and the last hour before sunset, the maximum deviation, which can be expected, should not be larger than 25%. Values of  $\varphi$  as a function of the time of day and day of the year were obtained and represented by the time-dependence of the angles  $\varphi$  and  $\theta$  (Figure 8) (Mazria, E. 1979). The result shown in Figure 9 corresponds to the shortest winter day, as well as for the autumn/spring equinox.

### Ground Irradiance in Greenhouses with a Reflecting Wall

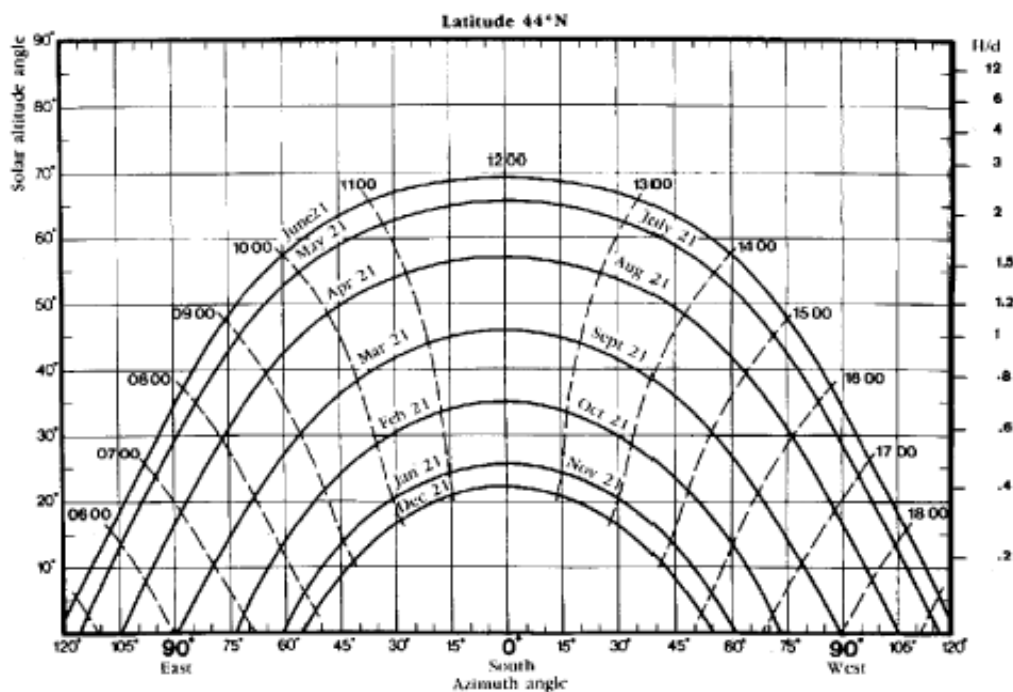
In the presence of a reflecting wall with a height equal to the width of the greenhouse ( $h=a$ ), the overall ground irradiance due to direct solar radiation is given by Eq. (15). Using the derived  $G_O^S$  value, as well as the time dependence

of  $\phi$  (assuming  $\rho = 1$ ), a calculation was made for a fixed reflecting wall inclined at an optimum angle without and with louvers. Calculations were also made for a reflector with an adjustable inclination to follow the increase/decrease of  $\phi$  during the day (type (c) as well as type (d)).

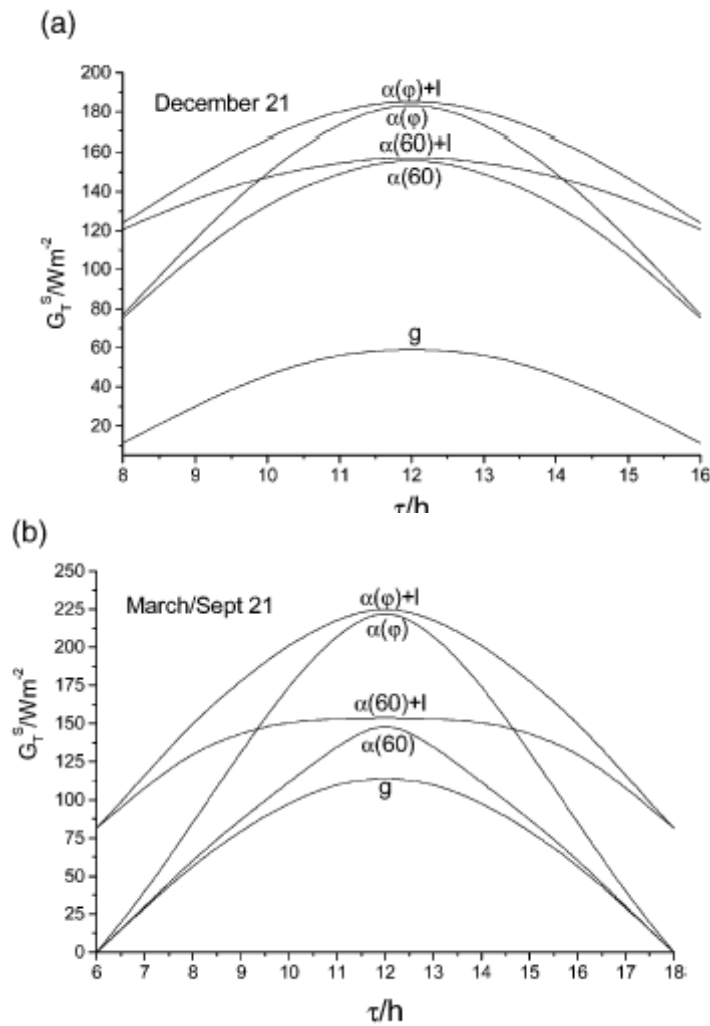
As indicated by Eq. (4),  $x_o$  depends on  $\phi$ . For certain fixed angles  $\alpha$  and  $\phi$ , in which  $x_o > a$ , some of the reflected radiation falls outside the greenhouse ( $x_o/h > 1$ ) and ground irradiance is even. However, for  $x_o < a$ , the insolation of the ground is not even. Some parts of the ground, away from the reflecting wall and close to the greenhouse southern side, are without reflected radiation. The advantage of a reflecting wall with an adjustable inclination is that the reflected radiation at all times covers the entire ground area in the greenhouse and hence the irradiance remains even throughout the day. The results of calculations of average greenhouse irradiance for the shortest winter day and for spring/autumn served as an example and are presented in Figure 9. (Limitations due to  $(S/S_o \neq 1)$  and  $(x_o < a)$  were taken into account). For the sake of comparison, at both dates the inclination of the fixed wall was taken to be  $60^\circ$  which is the optimal angle for the first date and less than optimal for second (Siddig, O. 2002).

It is of interest to estimate the enhancement coefficient  $\eta_w$  using Eq. (16). The latter is shown in Figure 10, together with the enhancement coefficients  $\eta_s$  (Eq. (9)) in parts of the greenhouse exposed to direct sunlight (within  $x_o < a$ ) for optimal inclination of fixed wall.

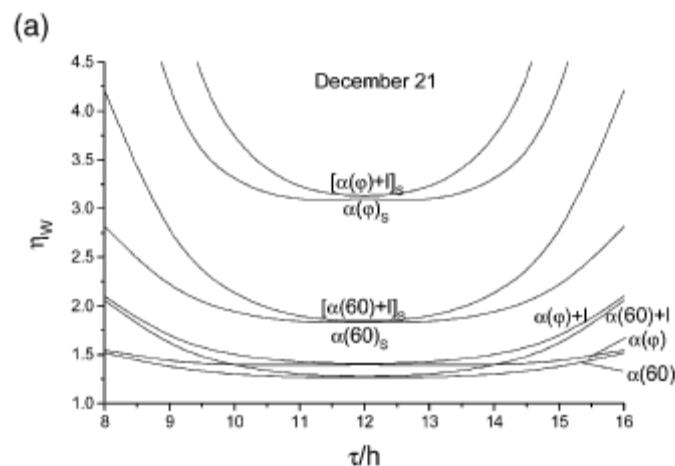
The overall daily energy gains obtained from Eq. (17) applied to reflecting panels of fixed inclination at different angles, as well as for those with adjustable inclinations with and without louvers, are given in Figure 11. As can be seen, the optimum inclination, from the point of view of energy gain, is different in December than in March/September. It shifts from  $60^\circ$  in the former case to  $70^\circ$  in the latter. As can be deduced from Figures 10 and 11, when compared to the irradiance and energy values obtainable in a classical greenhouse, on short winter days there is indeed a significant enhancement of both the average irradiance at the greenhouse ground and an overall energy gain during the entire day. The enhancements increase in order of increasing sophistication of the type of greenhouse and are particularly large in the morning and evening hours. As the length of day increases, accompanied by a widening of the span of the azimuth angle, the enhancement is reduced. Thus, at the equinox and in the case of fixed reflecting walls oriented north-to-south it becomes negligible, as most of the reflected radiation misses the greenhouse floor. In such a situation the use of the louvers becomes essential. Taking into account the situation shown in Figure 1, the enhancement of the insolation was indeed very large as was expected to be.



**Figure 8.** Dependence of the elevation and azimuth angle of the sun on the time of a day at different days of a year at NL  $44^\circ$  (Mazria, E. 1979).

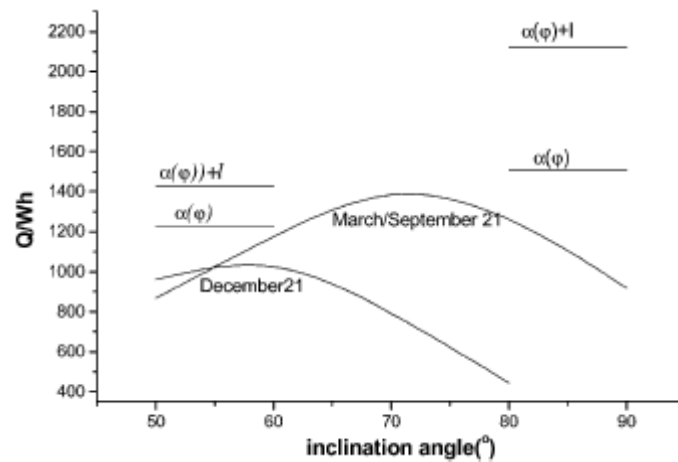


**Figure 9.** Calculated dependence of ground irradiance on time for the shortest day of the year and for equinox in a greenhouse with a reflecting wall inclined at an angle of  $60^\circ$ , ( $\alpha(60)$ ) with a reflecting wall with variable inclination ( $\alpha(\phi)$ ), without louvers and ( $\alpha(60) + 1$ ), ( $\alpha(\phi) + 1$ ) the same but with louvers.

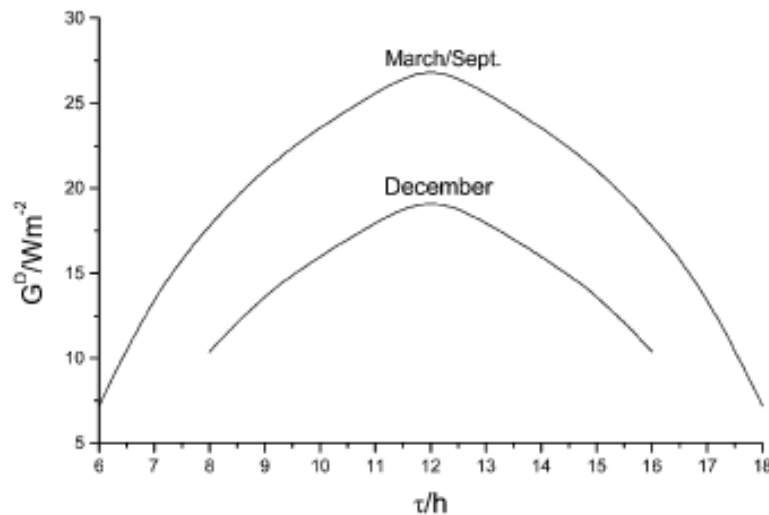


**Figure 10.** Dependence of the irradiance enhancement coefficient on time, the shortest day of the year and equinox at  $44^\circ$  NL in a greenhouse with reflecting walls inclined at optimum angles  $\alpha(60)$  and  $\alpha(70)$ , and with reflecting walls with variable inclinations.

In greenhouse type (d), each louver, when adjusted to the angle of the azimuth angle of the sun, casts a shadow on a part of its neighboring louver. The effect is significant, particularly in the early morning and late evening hours. Unless the entire reflecting wall is constructed as a single louver, the actual result will be somewhat smaller from the calculated value.



**Figure 11.** Dependence of the daily energy gain in different types of greenhouses. Different types illustrate the effects of the inclination angle of the wall at the shortest winter day and at equinox. The horizontal lines show the effects of different inclination angles without and with louvers.



**Figure 12** Ground irradiance from diffuse (sky) radiation from a clear sky at the shortest winter day and at equinox.

**The Effects of Diffuse Radiation**

Radiation was obtained on a cloudless, clear day from the hour of the day when the declining sun reached an elevation angle of 45° (characteristic of the apex at the equinox for 44° NL) until a few minutes after sunset. In order to assess  $G_o^D$  for clear days, the values to be multiplied by 3/2 as they were obtained from two-thirds of the hemisphere.

The results are shown in Figure 12. A different situation is encountered on a cloudy day. In this case,  $G_o^D$  can be obtained from the data of the National Solar Radiation Database (USA). If it is assumed that the DR (monthly average of diffuse radiation for a winter day) is approximately constant during the entire day, and if the case of the state of main taken as an example, then:

$$G_o^D = \frac{DR}{t} = 102 \text{ Wm}^{-2} \text{ (70)}$$

**Effects of Urban Density**

From psychological and sociological points of view, high population density and the effect of crowding are interesting topics, which have attracted much attention. A crowded and stressful urban environment may have unhealthy effects on the occupants due to air pollution and noise problems. On the other hand, the level of mobility and traffic speed will benefit the working and living of the people. Therefore, it should be noted that density and crowding are not necessarily found together. To handle population growth on a limited land basis, the word density is unavoidable. This, however, results in the establishment of a high-rise cityscape and compact urban settings. The effects of urban concentrated load centres and compactness of land use patterns will bring benefits to energy distribution and transport



system design, but crowded conditions may create congestion and undesirable local microclimate. Burchell and Listokin (Burchell, R.W., & Listokin, D. Editors. 1982) have discussed the urban energy advantage and believed that cities are more energy efficient for the following reasons:

- [1] The urban building stock, due its density and compactness, consumes less energy.
- [2] Cities benefit from advantageous transportation and commutation characteristics.
- [3] Cities can easily capitalise from emerging more efficient energy systems, and
- [4] High densities and mixing of land uses may contribute to better efficiency.

As population density increases, transportation options multiply and dependence areas, per capita fuel consumption is much lower in densely populated areas because people drive so much less. Few roads and commercially viable public transport are the major merits. On the other hand, urban density is a major factor that determines the urban ventilation conditions, as well as the urban temperature (Sitarz, D. Editor. 1992). The clamour all over the world for the need to conserve energy and the environment has intensified as traditional energy resources continue to dwindle whilst the environment becomes increasingly degraded.

**Table 1.** Effects of urban density on city’s energy demand.

Positive effects	Negative effects
<p><b>Transport:</b></p> <ul style="list-style-type: none"> <li>• Promote public transport and reduce the need for, and length of, trips by private cars.</li> </ul> <p><b>Infrastructure:</b></p> <ul style="list-style-type: none"> <li>• Reduce street length needed to accommodate a given number of inhabitants.</li> <li>• Shorten the length of infrastructure facilities such as water supply and sewage lines, reducing the energy needed for pumping.</li> </ul> <p><b>Thermal performance:</b></p> <ul style="list-style-type: none"> <li>• Multi-story, multiunit buildings could reduce the overall area of the building’s envelope and heat loss from the buildings.</li> </ul> <p><b>Natural lighting:</b></p> <ul style="list-style-type: none"> <li>• Shading among buildings could reduce solar exposure of buildings during the summer period.</li> </ul> <p><b>Energy systems:</b></p> <ul style="list-style-type: none"> <li>• District cooling and heating system, which is usually more energy efficiency, is more feasible as density is higher.</li> </ul> <p><b>Ventilation:</b></p> <ul style="list-style-type: none"> <li>• A desirable in flow pattern around buildings may be obtained by proper arrangement of high-rise building blocks.</li> </ul>	<p><b>Transport:</b></p> <ul style="list-style-type: none"> <li>• Congestion in urban areas reduces fuel efficiency of vehicles.</li> </ul> <p><b>Vertical transportation:</b></p> <ul style="list-style-type: none"> <li>• High-rise buildings involve lifts, thus increasing the need for electricity for the vertical transportation.</li> </ul> <p><b>Ventilation:</b></p> <ul style="list-style-type: none"> <li>• A concentration of high-rise and large buildings may impede the urban ventilation conditions.</li> </ul> <p><b>Urban heat island:</b></p> <ul style="list-style-type: none"> <li>• Heat released and trapped in the urban areas may increase the need for air conditioning.</li> <li>• The potential for natural lighting is generally reduced in high-density areas, increasing the need for electric lighting and the load on air conditioning to remove the heat resulting from the electric lighting.</li> </ul> <p><b>Use of solar energy:</b></p> <p>Roof and exposed areas for collection of solar energy are limited.</p>

All in all, denser city models require more careful design in order to maximise energy efficiency and satisfy other social and development requirements. Hence, building energy study provides opportunities not only for identifying energy and cost savings, but also for examining indoor and outdoor environment.

**Energy Saving in Buildings**

The nature of the switching regime; manual or automated, centralised or local, switched, stepped or dimmed, will determine the energy performance. Simple techniques can be implemented to increase the probability that lights are switched off (Kurata, K. 1983a). These include:

- Making switches conspicuous.
- Loading switches appropriately in relation to the lights.
- Switching banks of lights independently.
- Switching banks of lights parallel to the main window wall.

There are also a number of methods, which help reduce the lighting energy use, which, in turn, relate to the type of occupancy pattern of the building (Kurata, K. 1983a). The light switching options include:

- Centralised timed off (or stepped)/manual on.
- Photoelectric off (or stepped)/manual on.
- Photoelectric and on (or stepped), and photoelectric dimming.
- Occupant sensor (stepped) on/off (movement or noise sensor).

Likewise, energy savings from the avoidance of air conditioning can be very substantial. Whilst day-lighting strategies need to be integrated with artificial lighting systems in order to become beneficial in terms of energy use, reductions in overall energy consumption levels by employment of a sustained programme of energy consumption strategies and measures would have considerable benefits within the buildings sector. The perception often given however is that rigorous energy conservation as an end in itself imposes a style on building design resulting in a restricted aesthetic solution. Better perhaps would be to support a climate sensitive design approach which encompassed some elements of the pure conservation strategy together with strategies which work with the local ambient conditions making use of energy technology systems, such as solar energy, where feasible. In practice, low energy environments are achieved through a combination of measures that include:

- The application of environmental regulations and policy.
- The application of environmental science and best practice.
- Mathematical modelling and simulation.
- Environmental design and engineering.
- Construction and commissioning.
- Management and modifications of environments in use.

While the overriding intention of passive solar energy design is to achieve a reduction in purchased energy consumption, the attainment of significant savings is in doubt. Buildings consume energy mainly for cooling, heating and lighting as shown in Table 2. The energy consumption shown in the table was based on the assumption that the building operates within ASHRAE-thermal comfort zone during the cooling and heating periods (Kurata, K. 1983b). It is well known that thermal mass with night ventilation can reduce the maximum indoor temperature in buildings in summer (Critten, D. 1985). Hence, comfort temperatures may be achieved by proper application of passive cooling systems. However, energy can also be saved if an air conditioning unit is used (Critten, D. 1986). The result is a slow heating of the building in summer as the maximal inside temperature is reached only during the late hours when the outside air temperature is already low. The heat flowing from the inside heavy walls can be removed with good ventilation in the evening and night. Maximising the efficiency and benefit gained from a greenhouse can be achieved using various approaches, and employing different techniques that could be applied at the design, construction or operational stages. Greenhouse cultivation is one of the most absorbing and rewarding form of gardening for anyone who enjoys growing plants.

- Light building: no thermal mass, e.g., a mobile home.
- Medium-light building: light walls, but heavy floor, e.g., cement tiles on concrete floor, and concrete ceiling.
- Semi-heavy building: heavy floor, ceiling and external walls (20 cm concrete blocks) but light internal partitions (Gypsum boards).
- Heavy building: heavy floor, ceiling, external and internal walls (10 cm concrete blocks, with plaster on both sides).
- The exact reduction in the maximum indoor temperature depends on the amount of thermal mass, the rate of night ventilation, and the temperature swing between day and night.

**Table 2.** Energy-saving in buildings.

Passive Comfort Measures	Active Comfort Measures	Climatic zones			
		Mediterranean	Subtropical	Tropical	Desert
Natural ventilation		6	7	7	7
	Mechanical ventilation	4	5	6	6
Night ventilation		6	7	7	7
	Artificial cooling	3	5	5	6
Evaporative cooling		3	2	2	7

	Free cooling	5	6	6	7
Heavy-weight Construction		6	2	2	6
Light-weight construction		3	5	5	4
	Artificial heating	4	0	0	1
Solar heating		6	0	0	0
	Free heating	5	0	0	0
Incidental heat		4	0	0	0
Insulation and permeability		5	0	0	4
Solar control/shading		6	6	6	7
	Daytime artificial lighting	3	3	3	2
Day lighting features		6	5	5	4

\* 0 = not important, 4 = important, and 7 = very important (importance is rated from 0 to 7).

One can define five levels of thermal mass as follows:

### Energy Efficiency and Architectural Expression

Buildings are important consumers of energy and thus important contributors to emissions of greenhouse gases into the global atmosphere. The development and adoption of suitable renewable energy technology in buildings has an important role to play. A review of options indicates benefits and some problems (Kurata, K. 1983b). There are two key elements to the fulfilling of renewable energy technology potential within the field of building design; first the installation of appropriate skills and attitudes in building design professionals and second the provision of the opportunity for such people to demonstrate their skills. This second element may only be created when the population at large and clients commissioning building design in particular, become more aware of what can be achieved and what resources are required.

Terms like passive cooling or passive solar use mean that the cooling of a building or the exploitation of the energy of the sun is achieved not by machines but by the building's particular morphological organisation. Hence, the passive approach to themes of energy savings is essentially based on the morphological articulations of the constructions. For a design to be successful, it is crucial for the designer to have a good understanding of the use of the building. Few of the buildings had performed as expected by their designers. To be more precise, their performance had been compromised by a variety of influences related to their design, construction and operation. However, there is no doubt that the passive energy approach is certainly the one that, being supported by the material shape of the buildings has a direct influence on architectural language and most greatly influences architectural expressiveness (Andrews, R. *et al.*, 1982). Furthermore, form is a main tool in architectural expression. To give form to the material things that one produces is an ineluctable necessity. In architecture, form, in fact, summarises and gives concreteness to its every value in terms of economy, aesthetics, functionality and, consequently, energy efficiency (Perez, R. *et al.*, 1990). The target is to enrich the expressive message with forms producing an advantage energy-wise. Hence, form, in its geometric and material sense, conditions the energy efficiency of a building in its interaction with the environment. It is, then, very hard to extract and separate the parameters and the elements relative to this efficiency from the expressive unit to which they belong. By analysing energy issues and strategies by means of the designs, of which they are an integral part, one will, more easily, focus the attention on the relationship between these themes, their specific context and their architectural expressiveness. Many concrete examples and a whole literature have recently grown up around these subjects and the wisdom of forms and expedients that belong to millennia-old traditions has been rediscovered. Such a revisiting, however, is only, or most especially, conceptual, since it must be filtered through today's technology and needs; both being almost irreconcilable with those of the past. Two among the historical concepts are of special importance. One is rooted in the effort to establish rational and friendly strategic relations with the physical environment, while the other recognises the interactions between the psyche and physical perceptions in the creation of the feeling of comfort. The former, which may be defined as an alliance with the environment deals with the physical parameters involving a mixture of natural and artificial ingredients such as soil and vegetation, urban fabrics and pollution (Matusiak, B., & Aschehoug, O. 1998). The most dominant outside parameter is, of course, the sun's irradiation, our planet's primary energy source. All these elements can be measured in physical terms and are therefore the subject of science. Within the second concept, however, one considers the emotional and intellectual energies, which are the prime inexhaustible source of renewable power (Pucar, M. 1997). In this case, cultural parameters, which are not exactly measurable, are involved. Objective scientific measurement parameters tell us very little about the emotional way of perceiving, which influences the messages of human are physical sensorial organs. The perceptual reality arises from a multitude of sensorial components; visual, thermal, acoustic, olfactory and kinaesthetics. It can, also, arise from the organisational quality of the space in which different parameters come together, like the sense of order or of serenity. Likewise, practical evaluations, such as usefulness, can be involved too. The evaluation is a wholly subjective matter, but can be shared by a set of experiencing persons (Perez, R. *et al.*, 1992). Therefore, these cultural parameters could be different in different contexts in spite of the

inexorable levelling on a planet- wide scale. The scientifically measurable parameters can, thus, have their meanings very profoundly altered by the non-measurable, but describable, cultural parameters.

However, the low energy *target al.*, so means to eliminate any excess in the quantities of material and in the manufacturing process necessary for the construction of our built environment. This claims for a more sober, elegant and essential expression, which is not jeopardising at all, but instead enhancing, the richness and preciousness of architecture, while contributing to a better environment from an aesthetic viewpoint (Pucar, M. 1999). Arguably, the most successful designs were in fact the simplest. Paying attention to orientation, plan and form can have far greater impact on energy performance than opting for elaborate solutions (Mazria, E. 1979). Therefore, it is imperative that a designer fully informs key personnel, such as the quantity surveyor and client, about their design and be prepared to defend it. Therefore, the designer should have an adequate understanding of how the occupants or processes, such as ventilation, would function within the building. Thinking through such processes in isolation without reference to others can lead to conflicting strategies, which can have a detrimental impact upon performance. Likewise, if the design intent of the building is not communicated to its occupants, there is a risk that they will use it inappropriately, thus, compromising its performance. For example, occupants should be well informed about how to guard against summer overheating. If the designer opted for a simple, seasonally adjusted control; say, insulated sliding doors were to be used between the mass wall and the internal space. The lesson here is that designers must be prepared to defend their design such that others appreciate the importance and interrelationship of each component. A strategy will only work if each individual component is considered as part of the bigger picture. Failure to implement a component or incorrect installation, for example, can lead to failure of the strategy and consequently, in some instances, the building may not liked by its occupants due to its poor performance.

### **Sustainable Practices**

Within the last decade sustainable development and building practices have acquired great importance due to the negative impact of various development projects on the environment. In line with a sustainable development approach, it is critical for practitioners to create a healthy, and sustainable built environment (Pucar, M. 1999; Mazria, E. 1979; Siddig, O. 2002; & Burchell, R.W., & Listokin, D. Editors. 1982). In Europe, 50% of material resources taken from nature are building-related, over 50% of national waste production comes from the building sector and 40% of energy consumption is building-related (Andrews, R. *et al.*, 1982). Therefore, more attention should be directed towards establishing sustainable guidelines for practitioners. Furthermore, the rapid growth in population has led to active construction that, in some instances, neglected the impact on the environment and human activities. At the same time, the impact on the traditional heritage, an often-neglected issue of sustainability, has not been taken into consideration, despite representing a rich resource for sustainable building practices.

Sustainability has been defined as the extent to which progress and development should meet the need of the present without compromising the ability of the future generations to meet their own needs (Sitarz, D. Editor. 1992). This encompasses a variety of levels and scales ranging from economic development and agriculture, to the management of human settlements and building practices. This general definition was further developed to include sustainable building practices and management of human settlements. The following issues were addressed during the Rio Earth Summit in 1992 (Lobo, C. 1998):

- The use of local materials and indigenous building sources.
- Incentive to promote the continuation of traditional techniques, with regional resources and self-help strategies.
- Regulation of energy-efficient design principles.
- International information exchange on all aspects of construction related to the environment, among architects and contractors, particularly non-conventional resources.
- Exploration of methods to encourage and facilitate the recycling and reuse of building materials, especially those requiring intensive energy use during manufacturing, and the use of clean technologies.

### **The Objectives Of The Sustainable Building Practices Aim To:**

- Develop a comprehensive definition of sustainability that includes socio-cultural, bio-climate, and technological aspects.
- Establish guidelines for future sustainable architecture.
- Predict the CO<sub>2</sub> emissions in buildings.
- The proper architectural measure for sustainability is efficient, energy use, waste control, population growth, carrying capacity, and resource efficiency.
- Establish methods of design that conserve energy and natural resources.

A building inevitably consumes materials and energy resources. The technology is available to use methods and materials that reduce the environmental impacts, increase operating efficiency, and increase durability of buildings. Literature on green buildings reveals a number of principles that can be synthesised in the creation of the built environment that is sustainable. According to Lobo C. (1998), these are: land development, building design and construction, occupant considerations, life cycle assessment, volunteer incentives and marketing programmes, facilitate reuse and remodelling, and final disposition of the structure. These parameters and many more are essential for analysis, making them an important element of the design decision-making process. Today, architects should prepare for this as well as dealing with existing buildings with many unfavourable urban environmental factors, such as many spaces have no choice of orientation, and, often, set in noisy streets with their windows opening into dusty and polluted air and surrounding buildings overshadowing them.

### **Buildings and CO<sub>2</sub> Emission**

To achieve carbon dioxide, CO<sub>2</sub>, emission targets, more fundamental changes to building designs have been suggested (Kausch, A. 1998). The actual performance of buildings must also be improved to meet the emission targets. To this end, it has been suggested that the performance assessment should be introduced to ensure that the quality of construction, installation and commissioning achieve the design intent. Air-tightness and the commissioning of plant and controls are the main two elements of assessing CO<sub>2</sub> emission. Air-tightness is important as uncontrolled air leakage wastes energy. Uncertainties over infiltration rates are often the reason for excessive design margins that result in oversized and inefficient plants. The slow turnover in the building stock means that improved performance of new buildings will only cut CO<sub>2</sub> emissions significantly in the long-term. Consequently, the performance of existing buildings must be improved. For example, improving 3% of existing buildings would be more effective in cutting emissions than, say, improving the fabric standards for new non-domestic buildings and improving the efficiency of new air conditioning and ventilation systems (Kurata, K. 1983b).

### **Low Energy Buildings**

Cities need to take a close look at how to make more efficient use of resources while fulfilling the needs of the people. An energy dimension should be included in the development process to measure the sustainability of urban and building design and growth planning models. Previous experience in public transport systems indicates that density is conducive to profitability and efficiency (Omer, A.M. 2009). A compact urban form with vertical zoning through multi-level and multi-functional urban clusters may be an efficient option for high-density living. There are, however, opportunities for high-density cities to explore and develop effective energy technologies, which can take full advantage of the concentrated loads and high-rise context, such as using district energy systems and vertical landscaping (Perez, R. *et al.*, 1990). As low energy design is becoming more and more complicated, there is a need to develop analytical methods and skills, such as simulation and modelling techniques, for the evaluation of energy performance of buildings and the analysis of design options and approaches (Perez, R. *et al.*, 1990). Kausch, A. (1998) pointed out that low energy building design is compatible with a wide range of architectural styles. Studio Nicoletti (Nicoletti, S. 1998) also illustrated the methods of architectural expression for low energy buildings in their projects. For high-density conditions, some of their methods are still valid but adaptation or modification may be needed to satisfy the local requirements. Climate consideration is a key element and starting point for formulating building and urban design principles that aim at minimising the use of energy for environmental control. It should be noted that in urban areas, the group of buildings would in fact modify the climatic conditions surrounding it.

Measures to maximise the use of high-efficiency generation plants and on-site renewable energy resources are important for raising the overall level of energy efficiency. For renewable energy systems, energy storage is still the major technical constraint to their applications (Omer, A.M. 2008). Loads concentration in high-density cities might provide opportunities for better utilisation of renewable energy systems. At present, lack of incentives and shortage of land and space are the key factors limiting the deployment of renewable energy systems. To promote renewables, it is necessary to create new development patterns and shift from a centralised view of energy sector to a regional perspective (Omer, A.M. 2008).

One important aspect often being overlooked is the raising of awareness and the education about low energy design. More efforts are needed to educate the people and establish the culture so that more people would accept and consider low energy buildings an important element of their living and working environment. It is important to recognise that solutions to the energy problems are not simply a matter of applying technology and enforcement through legislation (Omer, A.M. 2008). It requires public awareness and participation as well. Therefore, only renewables are absolutely sustainable, and nuclear is more sustainable than fossil.

In summary, achieving low energy building requires comprehensive strategy that covers; not only building designs, but also considers the environment around them in an integral manner. Major elements for implementing such a strategy are as follows.

### *Efficiency Use of Energy*

- Climate responsiveness of buildings.
- Good urban planning and architectural design.
- Good house keeping and design practices.
- Passive design and natural ventilation.
- Use landscape as a means of thermal control.
- Energy efficiency lighting.
- Energy efficiency air conditioning.
- Energy efficiency household and office appliances.
- Heat pumps and energy recovery equipment.
- Combined cooling systems.
- Fuel cells development.

### *Utilise Renewable Energy*

- Photovoltaics.
- Wind energy.
- Small hydros.
- Waste-to-energy.
- Landfill gas.
- Biomass energy and biofuels.

### *Reduce Transport Energy*

- Reduce the need to travel.
- Reduce the level of car reliance.
- Promote walking and cycling.
- Use efficient public mass transport.
- Alternative sources of energy and fuels.

### *Increase Awareness*

- Promote awareness and education.
- Encourage good practices and environmentally sound technologies.
- Overcome institutional and economic barriers.
- Stimulate energy efficiency and renewable energy markets.

A novel mop fan has been implemented for studying the thermal behaviour in the greenhouse after evaporative cooling (fan) using a liquid desiccant potassium formate introduced at the inlet of a flexible fibre impeller. A novel air humidifier and/or dehumidifier systems using mop fans (indoor temperature and humidity) has been employed to enhance the performance of the system, hence, reducing energy consumption, decreasing load in the greenhouse, and reducing manufacturing cost. The system has been designed taking into account the meteorological conditions to control the environment inside the greenhouse. To supervise the growing of plants, outdoor and indoor temperatures, and relative humidity were measured. The indoor temperature measurements were made at the top and bottom of the greenhouse (in the middle and near the door). The system has allowed providing temperatures inside the experimental greenhouse favourable to most greenhouse plants (the comfort level for active healthy growth is 16-26°C). In the experimental greenhouse, the system has allowed a relative humidity range between 30%-65%, which is favourable to the plants. It, also, enabled the reduction of the difference between minimum and maximum temperatures so as to avoid sudden climatic variations. Recent advances in thin film coatings for greenhouse glass products provide a means of substantially reducing heat gain without proportionally reducing daylight transmittance. It means that the energy expenditures due to lighting can be minimised, while plants can enjoy more natural light and maintain visual contact with the outside environment. In recent years, research activities in the field of using desiccant-based air conditioning systems are finding applications in humidity control devices. With some modifications, these systems may be used for recovering water from ambient air in arid areas. Desiccant-based water recovery from atmospheric air systems has great potential for use in solar energy applications. The system involves night absorption of water vapour from ambient air and simultaneous desiccant regeneration and water vapour condensation during the daytime. The results of the experimental tests are encouraging, further research and development is necessary to get commercially interesting products. It is, also, interesting to develop further studies about the utilisation of additional coatings that could reduce the heat loss in winter and limit the heat penetration in summer.

**Conclusion**

The introduction of a reflecting wall at the back of a greenhouse considerably enhances the solar radiation that reaches the ground level at any particular time of the day. Hence, the energy balance was significantly shifted towards conservation of classical energy for heating or lighting. The four-fold greater amount of energy that can be captured by virtue of using a reflecting wall with an adjustable inclination and louvers during winter attracts special attention. When sky (diffuse) radiation that was received by the ground in amounts shown in Figure 12, were taken into account, the values of the enhancement coefficients were reduced to some extent: this was due to the fact that they added up to the direct radiation from the sun in both new and classical greenhouses. There is also an ironing out effect expressed in terms of the ratios between peak and average insulations.

Finally, the presented theory can be used to calculate the expected effects of the reflecting wall at any particular latitude, under different weather conditions, and when the average numbers of clear days are taken into account. Thereby an assessment of the cost of a particular setup can be obtained. Under circumstances of a few clear days, it may still be worthwhile from a financial point of view to turn a classical greenhouse into one with a reflecting wall by simply covering the glass wall on the north-facing side with aluminum foil with virtually negligible expenditure.

As cities represent a significant source of growth in global energy demand, their energy use, associated environmental impacts, and demand for transport services create great pressure to global energy resources. It is found that densification of towns could have both positive and negative effects on the total energy demand. With suitable urban and building design details, population should and could be accommodated with minimum worsening of the environmental quality.

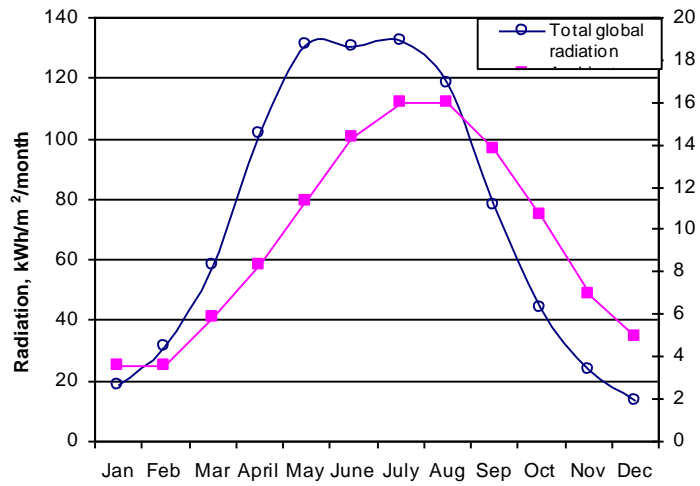
**Appendix 1. Total Measured Radiation over Nottingham [37]**

**Appendix (1.1).** Temperature in January 2003

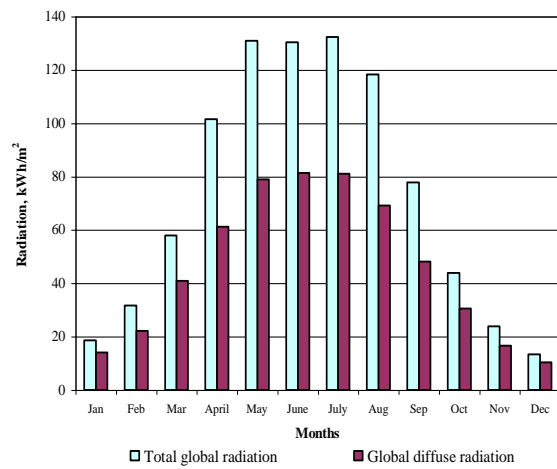
<b>Time</b>	<b>Ambient temperature</b>	<b>Bottom temperature</b>	<b>Top temperature</b>
09:00	17.5	16.2	17.5
10:00	17.7	16.1	17.4
11:00	18.2	16.1	17.2
12:00	18.8	16.4	17.2
13:00	19.8	17.9	18.6
14:00	20.8	18.5	19.6
15:00	20.3	17.5	19.3
16:00	20.1	17.4	18.2
17:00	19.8	17.3	18.1

**Appendix (1.2).** Total Radiation and Ambient Temperature

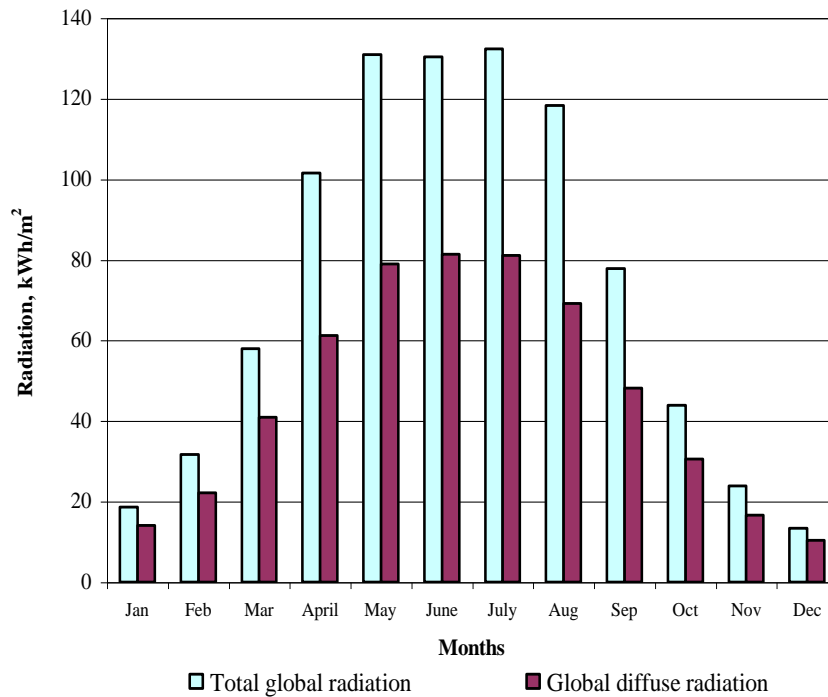
<b>Month</b>	<b>Total global radiation</b>	<b>Diffuse radiation</b>	<b>Ambient temperature</b>
January	18.6	14.1	3.6
February	31.6	22.2	3.6
March	58	40.9	5.8
April	101.5	61.2	8.3
May	130.9	78.9	11.3
June	130.3	81.4	14.3
July	132.4	81.1	16
August	118.3	69.2	16
September	77.8	48.2	13.8
October	43.9	30.5	10.7
November	23.8	16.6	6.9
December	13.4	10.4	4.9



**Appendix (1.3).** Total global and diffuse radiation.

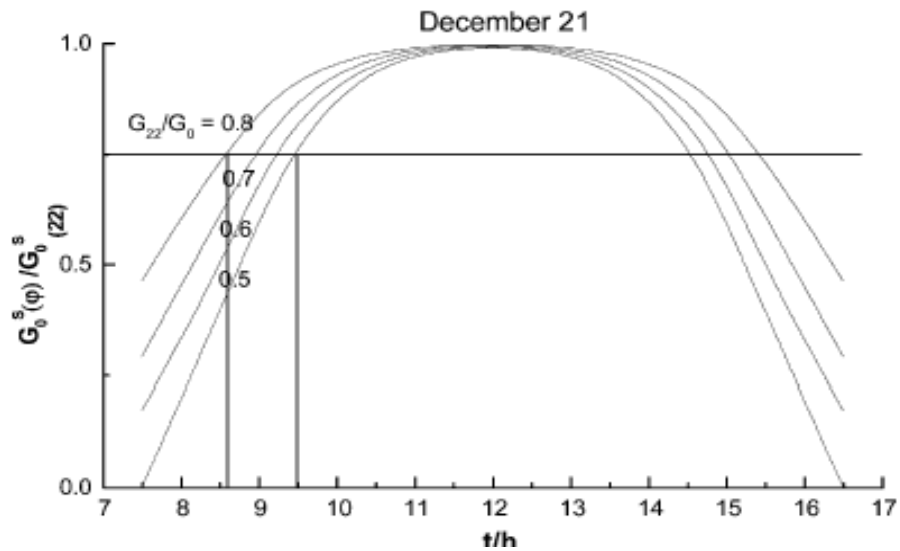


**Appendix (1.4).** Enhancement of solar radiation in greenhouse.

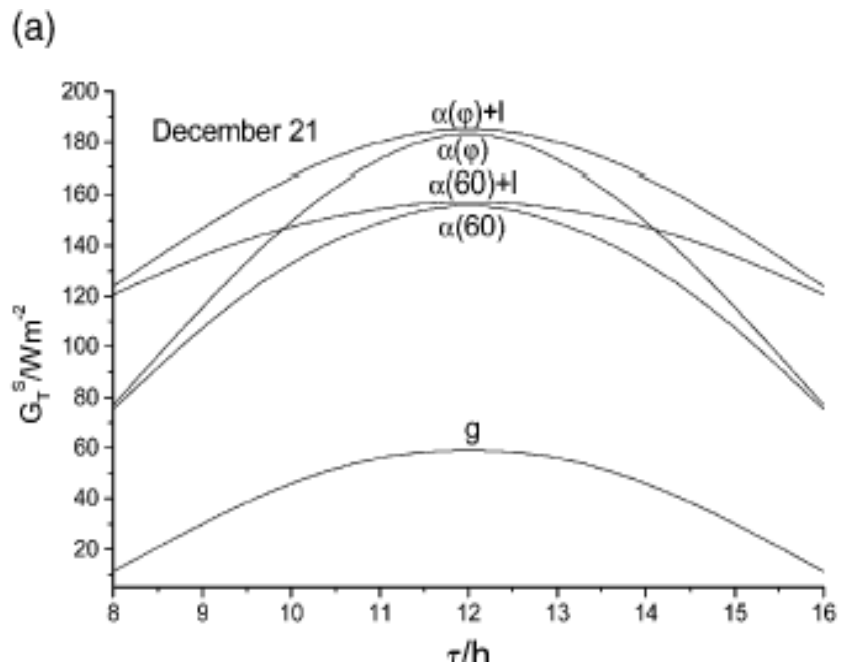


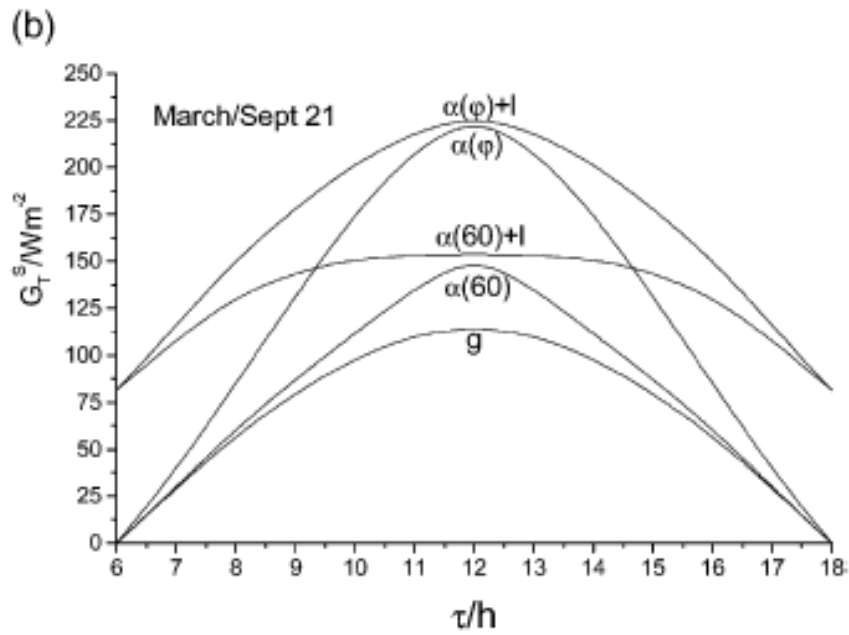
**Appendix (1.5).** A Schematic representation of the earth and its atmosphere with sunrays falling at an inclination  $\Phi$  with respect to the horizon.



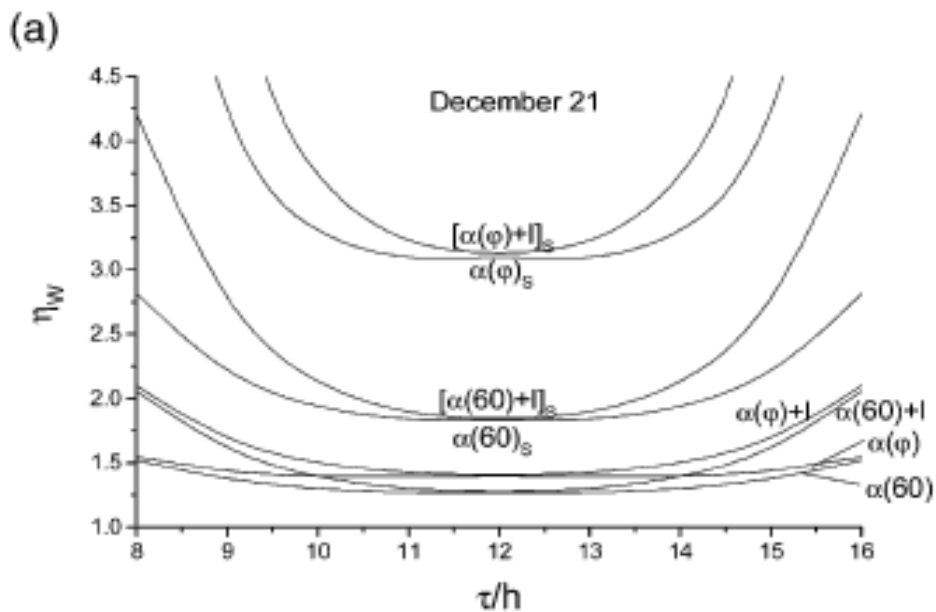


**Appendix (1.6).** Calculated values of normal irradiance by solar rays relative to the values obtained at the apex on December 21 for different transmittance by the atmosphere.

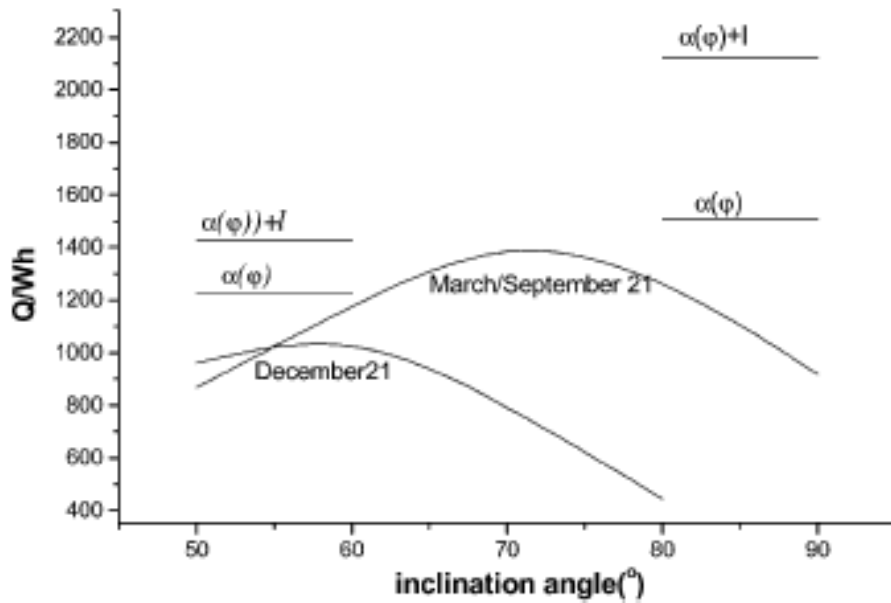




**Appendix (1.7).** Calculated dependence of ground irradiance on time for the shortest day of the year and for equinox in a greenhouse with a reflecting wall inclined at an angle of  $60^\circ$ , ( $\alpha(60)$ ) with a reflecting wall with variable inclination ( $\alpha(\varphi)$ ), without louvers and ( $\alpha(60)+l$ ), ( $\alpha(\varphi)+l$ ) the same but with louvers.

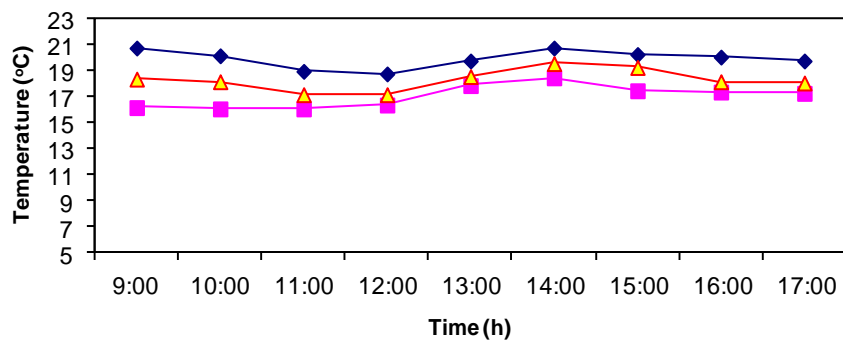


**Appendix (1.8).** Dependence of the irradiance enhancement coefficient on time, the shortest day of the year and equinox at  $44^\circ$  NL in a greenhouse with reflecting walls inclined at optimum angles  $\alpha(60)$  and  $\alpha(70)$ , and with reflecting walls with variable inclinations.



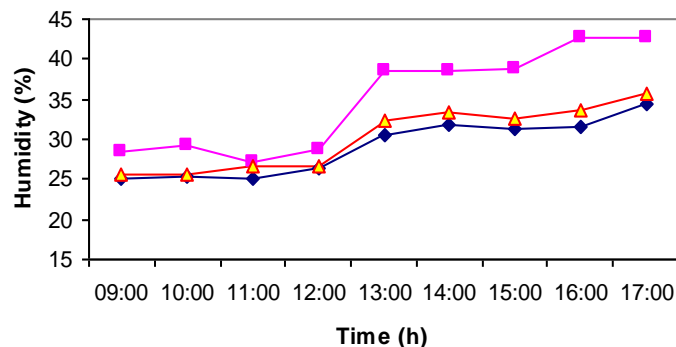
**Appendix (1.9).** Dependence of the daily energy gain in different types of greenhouses. Different types illustrate the effects of the inclination angle of the wall at the shortest winter day and at equinox. The horizontal lines show the effects of different inclination angles without and with louvers .

**Appendix 2. Experimental Results**



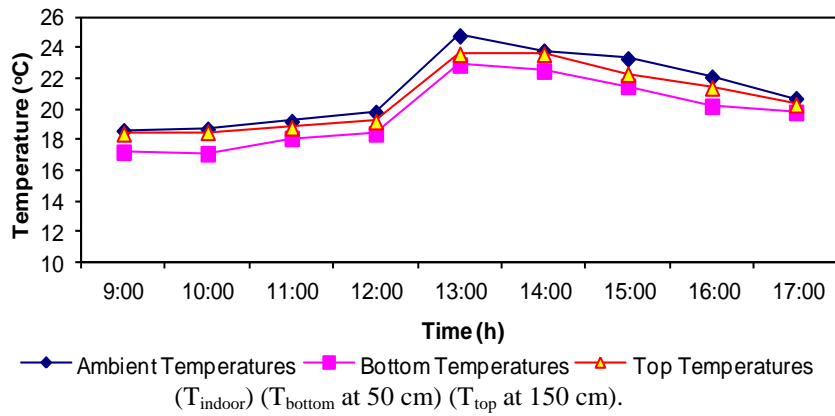
◆ Ambient Temperature    ■ Bottom Temperature    ▲ Top Temperature  
( $T_{\text{indoor}}$ ) ( $T_{\text{bottom}}$  at 50 cm) ( $T_{\text{top}}$  at 150 cm)

**Appendix 2.1.** Temperature variation in January.

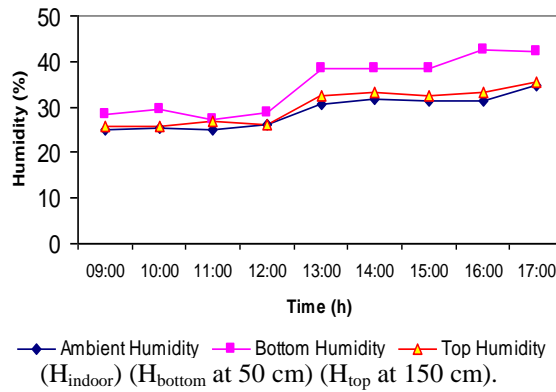


◆ Ambient humidity    ■ Bottom humidity    ▲ Top Humidity  
( $H_{\text{indoor}}$ ) ( $H_{\text{bottom}}$  at 50 cm) ( $H_{\text{top}}$  at 150 cm).

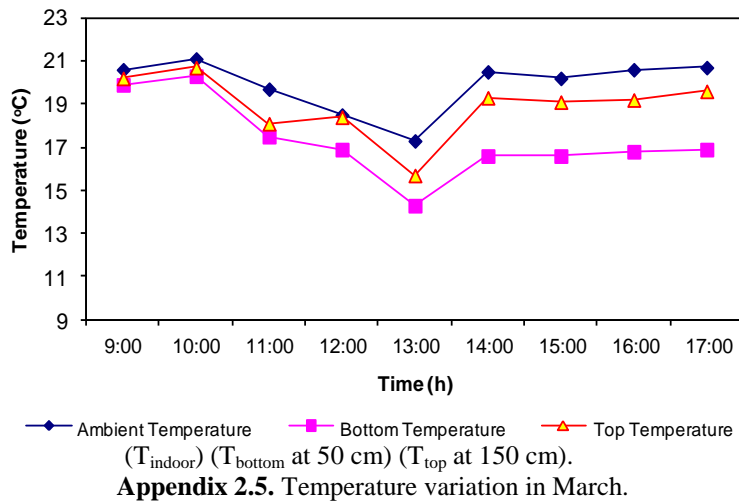
**Appendix 2.2.** Average daily variation of humidity in January.



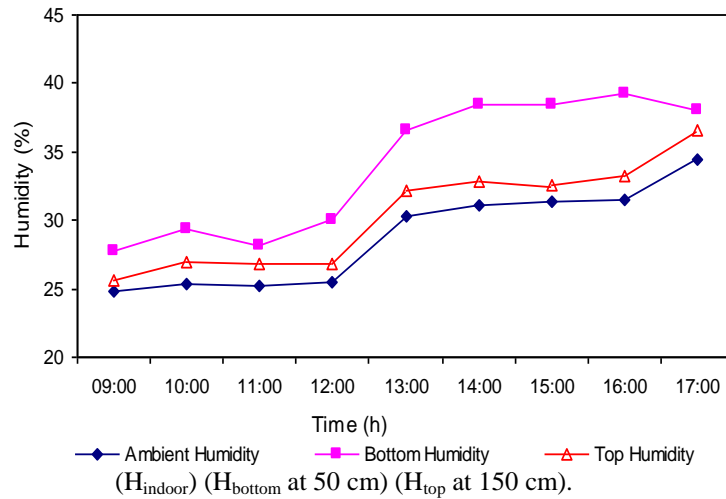
**Appendix 2.3.** Temperature variation in February.



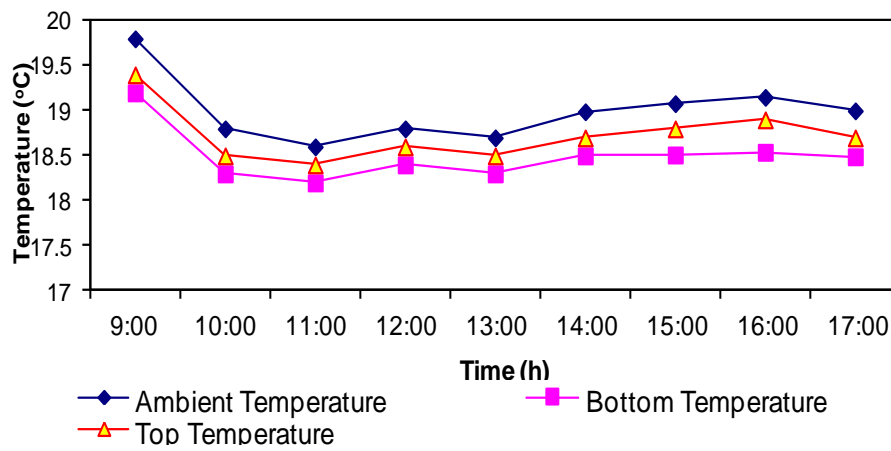
**Appendix 2.4.** Average daily variation of humidity in February.



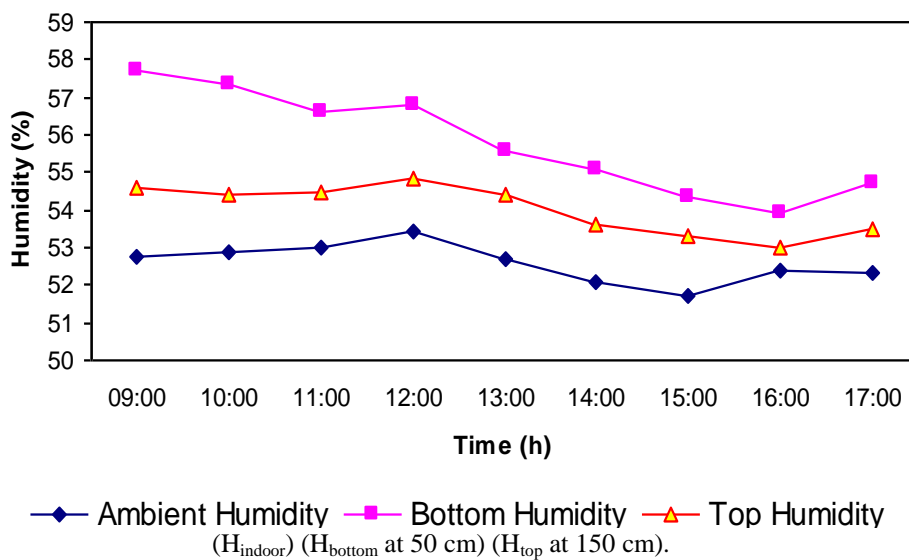
**Appendix 2.5.** Temperature variation in March.



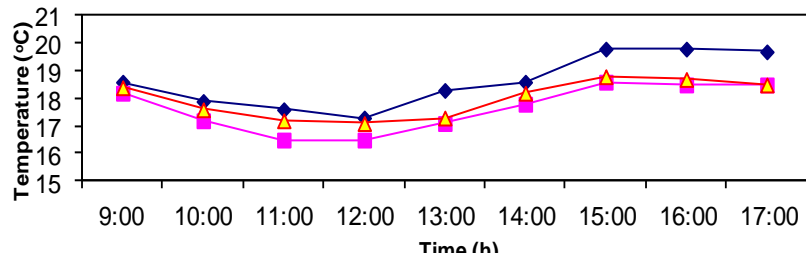
**Appendix 2.6.** Average daily variation of humidity in March.



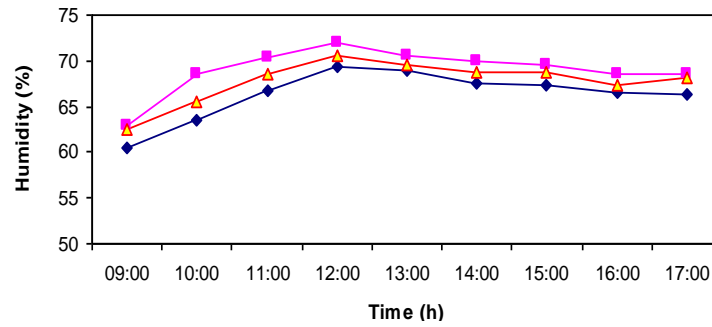
**Appendix 2.7.** Temperature variation in May.



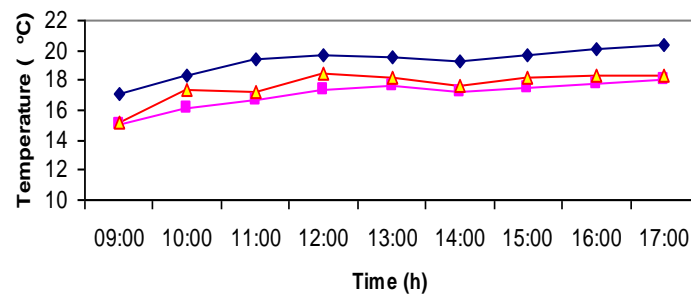
**Appendix 2.8.** Average daily variation of humidity in May.



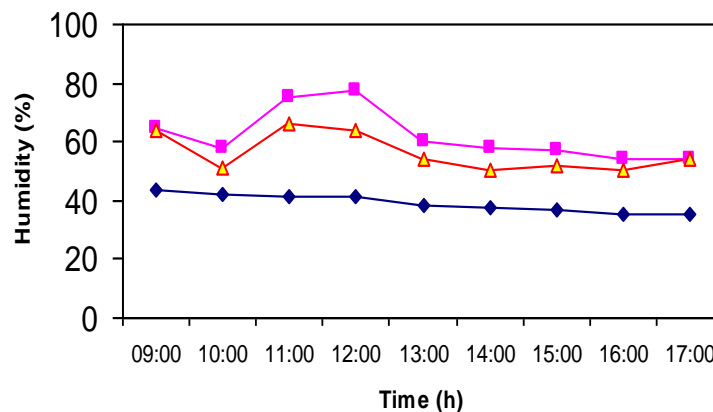
◆ Ambient Temperature    ■ Bottom Temperature    ▲ Top Temperature  
 ( $T_{\text{indoor}}$ ) ( $T_{\text{bottom}}$  at 50 cm) ( $T_{\text{top}}$  at 150 cm).  
**Appendix 2.9.** Temperature variation in June.



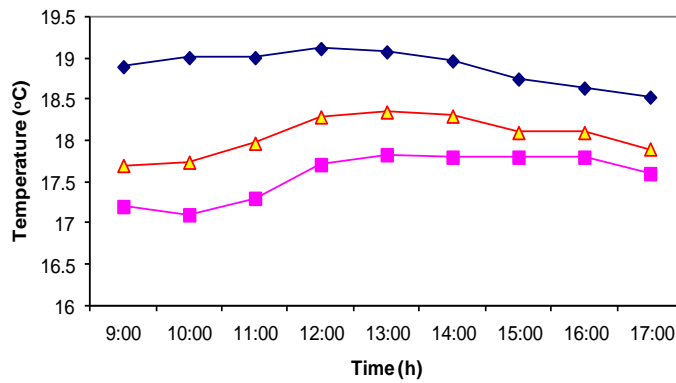
◆ Ambient Humidity    ■ Bottom Humidity    ▲ Top Humidity  
 ( $H_{\text{indoor}}$ ) ( $H_{\text{bottom}}$  at 50 cm) ( $H_{\text{top}}$  at 150 cm).  
**Appendix 2.10.** Average daily variation of humidity in June.



◆ Ambient Temperature    ■ Bottom Temperature    ▲ Top Temperature  
 ( $T_{\text{indoor}}$ ) ( $T_{\text{bottom}}$  at 50 cm) ( $T_{\text{top}}$  at 150 cm).  
**Appendix 2.11.** Temperature variation in July.

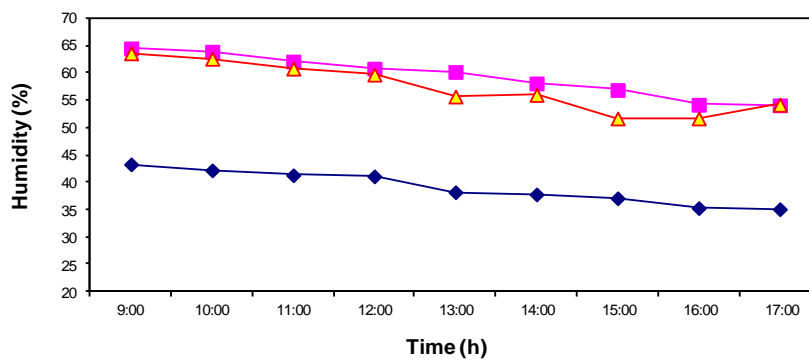


◆ Ambient Humidity    ■ Bottom Humidity    ▲ Top Humidity  
 ( $H_{\text{indoor}}$ ) ( $H_{\text{bottom}}$  at 50 cm) ( $H_{\text{top}}$  at 150 cm).  
**Appendix 2.12.** Average daily variation of humidity in July.



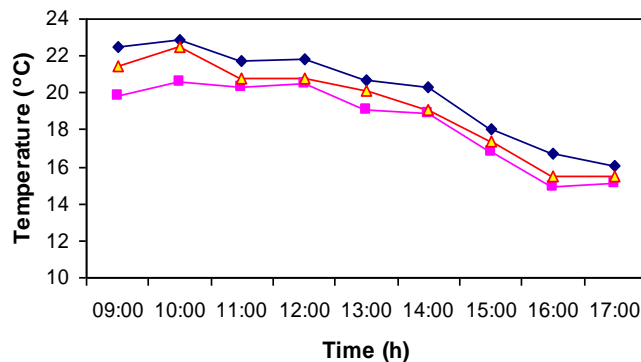
◆ Ambient Temperature    ■ Bottom Temperature    ▲ Top Temperature  
 ( $T_{\text{indoor}}$ ) ( $T_{\text{bottom}}$  at 50 cm) ( $T_{\text{top}}$  at 150 cm).

**Appendix 2.13.** Temperature variation in August.



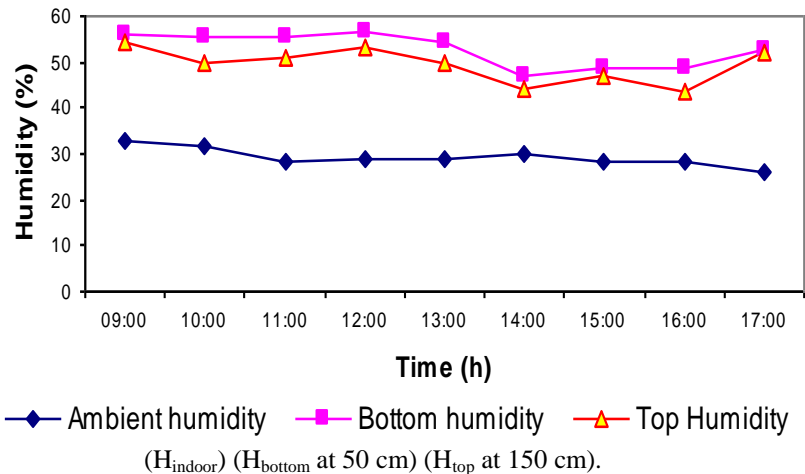
◆ Ambient Humidity    ■ Bottom Humidity    ▲ Top Humidity  
 ( $H_{\text{indoor}}$ ) ( $H_{\text{bottom}}$  at 50 cm) ( $H_{\text{top}}$  at 150 cm).

**Appendix 2.14.** Average daily variation of humidity in August.

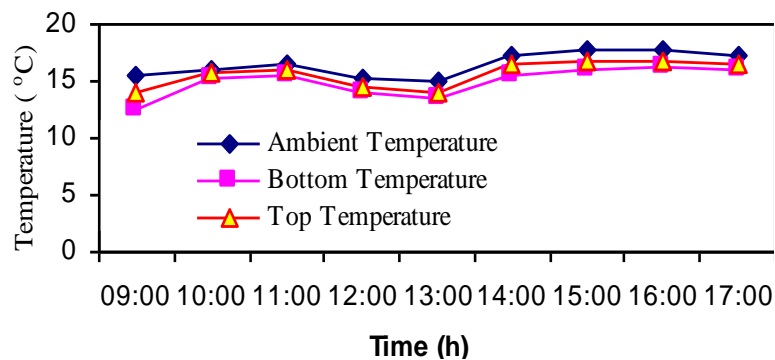


◆ Ambient Temperature    ■ Bottom Temperature    ▲ Top Temperature  
 ( $T_{\text{indoor}}$ ) ( $T_{\text{bottom}}$  at 50 cm) ( $T_{\text{top}}$  at 150 cm).

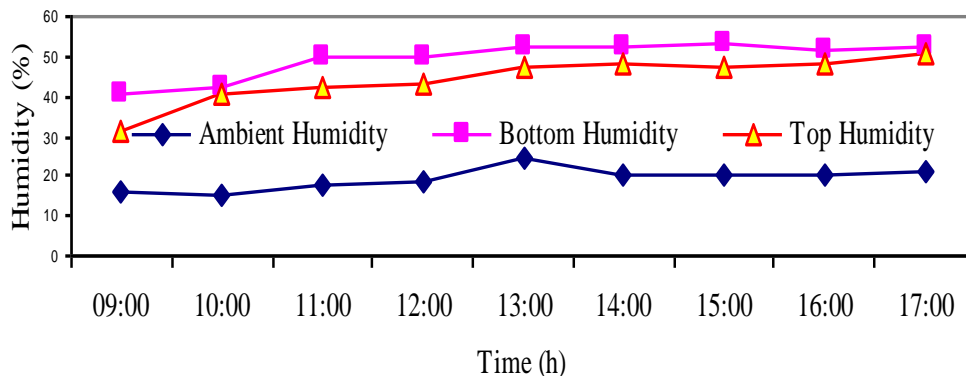
**Appendix 2.15.** Temperature variation in September.



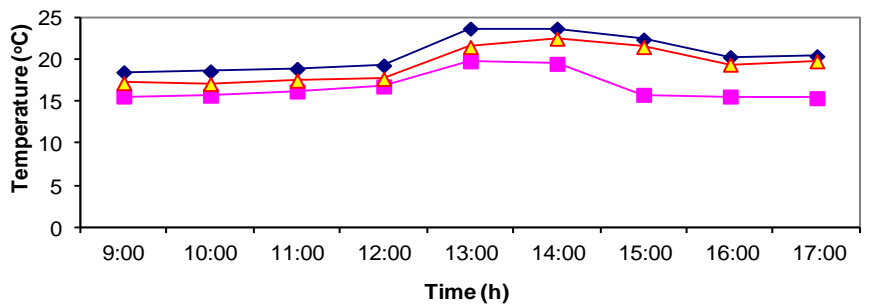
( $H_{indoor}$ ) ( $H_{bottom}$  at 50 cm) ( $H_{top}$  at 150 cm).  
**Appendix 2.16.** Average daily variation of humidity in September.



( $T_{indoor}$ ) ( $T_{bottom}$  at 50 cm) ( $T_{top}$  at 150 cm).  
**Appendix 2.17.** Temperature variation in October.

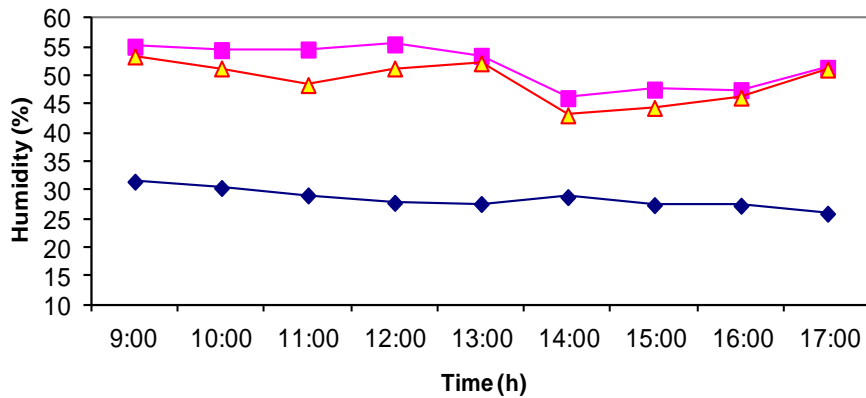


( $H_{indoor}$ ) ( $H_{bottom}$  at 50 cm) ( $H_{top}$  at 150 cm).  
**Appendix 2.18.** Average daily variation of humidity in October.

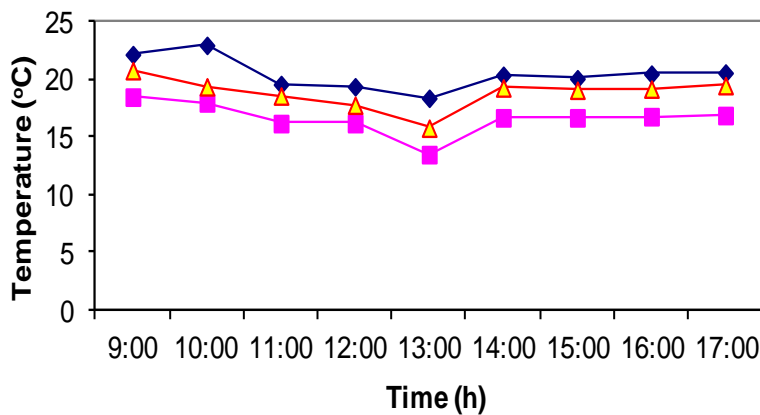


( $T_{indoor}$ ) ( $T_{bottom}$  at 50 cm) ( $T_{top}$  at 150 cm).  
**Appendix 2.19.** Temperature variation in November.

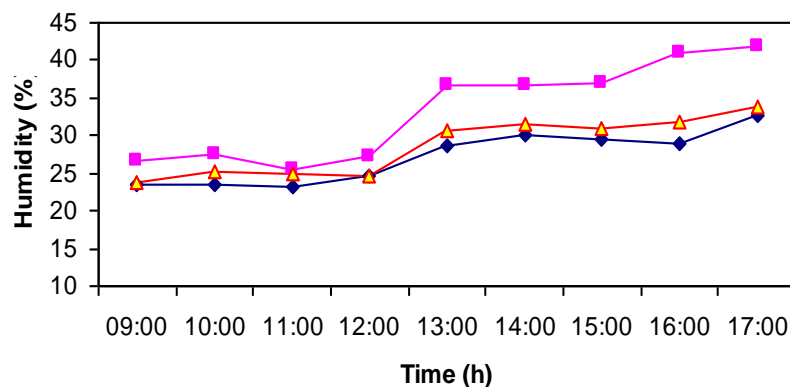




Appendix 2.20. Average daily variation of humidity in November.



Appendix 2.21. Temperature variation in December.



Appendix 5.22. Average daily variation of humidity in December.

### List of Symbols and Abbreviations

a	Greenhouse width (m)
b	Greenhouse length (m)
$C_{p,air}$	Specific heat of air ( $\text{kJ kg}^{-1} \text{K}^{-1}$ )
DR	Monthly average of diffuse radiation for a winter day ( $\text{Wm}^{-2}$ )

$G_T$	Average ground irradiance in the presence of a reflecting wall ( $Wm^{-2}$ )
$G_O^S(\varphi)$	Solar irradiance (radiation at a plane normal to incident solar rays) ( $Wm^{-2}$ )
$G_O^D$	Diffuse (sky) irradiance ( $Wm^{-2}$ )
$G_G^D$	Ground irradiance arising from diffuse radiation by direct insolation ( $Wm^{-2}$ )
$G_T^D$	Total diffuse irradiance ( $Wm^{-2}$ )
$G_R^D$	Reflected diffuse radiation ( $Wm^{-2}$ )
$G_T^S$	Total ground irradiance from sunlight ( $Wm^{-2}$ )
$G_{T,av}^S$	Average total ground irradiance from sunlight ( $Wm^{-2}$ )
$G_G^S$	Ground irradiance from direct insolation ( $Wm^{-2}$ )
$G_R^S$	Ground irradiance from the reflector ( $Wm^{-2}$ )
$h$	Height of the reflecting wall (m)
$m$	Air mass flow rate ( $kgs^{-1}$ )
$P$	Part of the ground not illuminated by sunlight
$q$	Volumetric airflow rate ( $m^3s^{-1}$ )
$Q_T^S$	Daily energy gain from solar radiation ( $Whm^{-2}$ )
$Q_G^S$	Daily energy gain from ground irradiance ( $Whm^{-2}$ )
$R$	Earth's radius (km)
$\Delta R$	Thickness of the atmosphere (km)
$S_V$	Vertical width of the sunbeam falling onto a reflecting wall (m)
$S_h$	Horizontal width of the sunbeam falling onto a reflecting wall (m)
$S_\varepsilon$	Width of a beam of diffuse light arriving at an angle $\varepsilon$ (degree)
$S_O$	Ground surface area of the greenhouse ( $m^2$ )
$S$	Ground surface area illuminated by reflection ( $m^2$ )
$T$	Air temperature ( $^{\circ}C$ )
$X_O$	Distance from the reflecting wall traversed by reflected radiation (m)
$z,y$	Auxiliary variables
$\alpha$	Inclination angle of the reflecting wall (degree)
$\alpha(\varphi)$	Changing inclination of the reflecting wall (degree)
$\alpha_{soil}$	Thermal diffusivity ( $m^2s^{-1}$ )
$\beta,\gamma$	Auxiliary angles (degree)
$\varepsilon$	Auxiliary angle (degree)
$\eta_D$	Reduction coefficient of diffuse ground radiation (%)
$\eta_S$	Enhancement coefficient of direct ground illumination by reflected sunlight (%)
$\eta_T$	Total enhancement coefficient (%)
$\eta_W$	Enhancement coefficient of average irradiance (%)
$\eta_{Wh}^S$	Energy enhancement coefficient (%)
$\varphi$	Incident angle of the sun (degree)
$\theta$	Azimuth angle of the sun (degree)
$\theta_C$	Critical azimuth angle at which half of the ground area is not receiving the reflected light (degree)
$\rho_a$	Air density ( $kgm^{-3}$ )
$\rho$	Reflectivity coefficient of the wall (%)
$\tau$	Time of day (h)
$\tau$	Transmission coefficient ( $km^{-1}$ )

## References

1. Abdel, E. (1994). Low-energy buildings. *Energy and Buildings*, 21(3), 169-174.
2. Achard, P., & Gicquel, R. (1986). *European passive solar handbook*. Brussels: Commission of the European Communities.
3. Andrews, R., Bailey, B. J., & Cotton, R. F. (1982). The effect on glasshouse light transmission of covering the walls and floor with plastics materials. Div. Note DN/1222, Natn. Inst. Agric. Engng. Silsoe.
4. Bos, E., Vu, M., Massiah, E., & Bulatao, R. (1994). *World Population Projections, 1994–95 edition*, published for the World Bank. The John Hopkins University Press, Baltimore and London.
5. Burchell, R.W., & Listokin, D. Editors. (1982). *Energy and land use*. New Jersey. USA: Centre for Urban Policy Research. State University of New Jersey.
6. CIBSE. (1998). *Energy efficiency in buildings: CIBSE guide*. London: Chattered Institution of Building Services Engineers. 1998.
7. Critten, D. (1985). The use of reflection in Venetian blinds to enhance irradiance in greenhouses. *Solar Energy*, 34 (1), 83-92.
8. Critten, D. (1986). Light enhancement using reflectors arranged on a Venetian blind configuration. *Solar Energy*, 37 (6), 445-56.
9. DEFRA. (2002). *Energy Resources*. Sustainable Development and Environment. UK.
10. DETR. (1994). *Best practice programme-introduction to energy efficiency in buildings*. UK Department of the Environment, Transport and the Regions.
11. Dincer, I. (2002). The role of energy in energy policy making. *Energy Policy*, 30(2), 137-149.
12. Duchin, F. (1995). *Global scenarios about lifestyle and technology, the sustainable future of the global system*. Tokyo: United Nations University.
13. *Energy use in offices*. (2000). *Energy Consumption Guide 19 (ECG019)*. Energy efficiency best practice programme. UK Government.
14. FSEC. (1998). *Principles of low energy building design in warm, humid climates*. Cape Canaveral (FL): Florida Solar Energy Centre (FSEC).
15. Givoni, B. (1994). *Passive and low energy cooling of buildings*. New York: Van Nostrand Reinhold.
16. IPCC. (2001). *Climate change 2001 (3 volumes)*. United Nations International Panel on Climate Change. Cambridge University Press. UK.
17. Kausch, A. (1998). Is low-energy building compatible with any architectural style? In: *Environmental friendly cities*. Proceedings of PLEA 98, Lisbon. Portugal. 217-220.
18. Kurata, K. (1983a). Studies on improvements of the light environment in greenhouses. (i) Applications of a Fresnel prism to greenhouse covering. *J. Agric. Met.*, 39 (2), 103-106.
19. Kurata, K. (1983b). Studies on improvements of the light environment in greenhouses. (ii) Utilisation of reflective blinds. *J. Agric. Met.*, 39 (3), 219-23.
20. Levine, M., & Hirose, M. (1995). *Energy efficiency improvement utilising high technology: An assessment of energy use in industry and buildings*. Report and Case Studies. London: World Energy Council, 46-150.
21. Lobo, C. (1998). *Defining a sustainable building*. In: *Proceedings of 23rd National Passive Conference, ASES'98*. Albuquerque (USA): American Solar Energy Society.
22. Matusiak, B., & Aschehoug, O. (1998). Daylighting systems for linear atria at high latitudes. In *International Daylighting Conference*, Ottawa: Natural Resources Canada (pp. 333-340).
23. Mazria, E. (1979). *The passive solar energy book*. Emmaus (PA, USA): Rodale Press.
24. Nicoletti, S. (1998). Architectural expression and low energy design. *Renewable Energy*, 15, 32-41.
25. Omer, A.M. (2008). Energy demand for heating and cooling equipment systems and technology advancements. In: *Natural Resources: Economics, Management and Policy*, 131-165.
26. Omer, A.M. (2009). Energy use and environmental: impacts: a general review, *Journal of Renewable and Sustainable Energy*, 1 (053101), 1-29, United State of America, September 2009.
27. Owens, S. (1986). *Energy, planning and urban form*. London: Pion.
28. Parikh, J., Smith, K., & Laxmi, V. (1999). Indoor air pollution: a reflection on gender bias. *Economic and Political Weekly*, 539-544.
29. Perez, R., Ineichen, P., Seals, R., Michalsky, J., & Stewart, R. (1990). Modeling daylight availability and irradiance components from direct and global irradiance. *Solar energy*, 44(5), 271-289.
30. Pucar, M. (1997). *Greenhouse with a mobile reflecting wall*. Yug. Patent No. 283/97.
31. Pucar, M. (1999). Parameters of planning and designing of glass-covered space as an element of bioclimatic architecture. Beograd.
32. Rees, W.E. (1999). The built environment and the ecosphere: a global perspective. *Building Research and information*, 27 (4), 206-20.

33. Siddig, O. (2002). Measurement of global and diffuse radiation.
34. Sitarz, D. Editor. (1992). *Agenda 21: The Earth Summit Strategy to save our planet*. Boulder (CO): Earth Press.
35. State Projects. (1993). *Building Energy Manual*. Australia: NSW Public Works.
36. Todesco, G. (1996). Super-efficient buildings: how low can you go? *ASHRAE Journal*. 38(12), 35-40.
37. Treloar, G. J., Tucker, S. N., & Fay, R. (1998). *Proceedings of the Embodied Energy: The Current State of Play: Seminar, Held at Deakin University, Geelong, Australia, 28th-29th November, 1996*. Deakin University, School of Architecture and Building.
38. UNIDO. (1997). *Changing courses sustainable industrial development, as a response to agenda 21*. Vienna.
39. VAN Schijndel, P., Den Boer, J., Janssen, F., Mrema, G., & Mwaba, M. (1998). Exergy analysis as a tool for energy efficiency improvements in Tanzania and Zambia industries. ICESD International Conference Engineering for Sustainable development. University of Dar Es Salaam. Tanzania. July 27-29.
40. Watson, D. editor. (1993). *The energy design handbook*. Washington (DC): American Institute of Architects Press.
41. *World Energy Outlook*. (1995). International Energy Agency. OECD Publications. 2 rue Andre Pascal. Paris. France. 1995.
42. WRI (World Resource Institute). (1994). *World Resources: A guide to the Global Environment. People and the Environment*. Washington. USA.
43. Yuichiro, K., Cook, J., & Simos, Y. (1991). Editors. *Passive and low energy architecture*. In: *Special Issue of Process Architecture*. Tokyo (Japan).